

The GP2015 is a small format RF Front-end for Global Positioning System (GPS) receivers. Equivalent in performance to the GP2010 but in a TQFP package, this product is suited for size-critical applications as the RF area can be reduced by a factor of two to three using miniature surface mount passive components. The GP2015 is designed to operate from either 3 or 5 Volt supplies.

The input to the device is the L1 (1575.42MHz) Coarse-Acquisition (C/A) code Global Positioning signal from an antenna (via a low-noise pre-amplifier). The output is 2-bit quantised for subsequent signal processing in the digital domain. The GP2015 contains an on-chip synthesiser, mixers, AGC and a quantiser which provides Sign and Magnitude digital outputs. A minimum of external components is required to make a complete GPS front-end.

The device has been designed to operate with the GP2021 12-channel Global Positioning Correlator, and DW9255 SAW filter, both also available from Mitel Semiconductor.

### FEATURES

- Ultra miniature TQFP package
- Low Voltage Operation (3V - 5V)
- Low Power - 200mW typ. (3V supply)
- C/A Code Compatible
- On-chip PLL Including Complete VCO
- Triple Conversion Receiver
- 48-Lead Surface Mount Quad Flat-Pack Package
- Sign and Magnitude Digital Outputs
- Compatible with GP2021 CMOS Correlator

### APPLICATIONS

- C/A Code Global Positioning by Satellite Receivers
- Time Standards
- Navigation
- Surveying

### ORDERING INFORMATION

The GP2015 is available in 48 pin TQFP package to Industrial (-40°C to +85°C) grade.

### ORDERING CODE

**GP2015 IG FP1R** Industrial - Plastic 48-pin TQFP

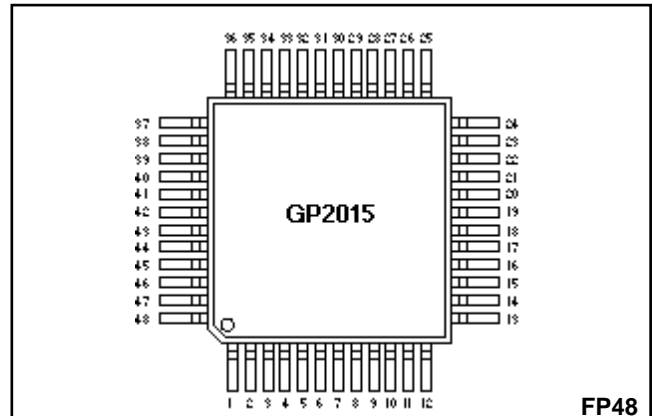

Pin	Name	Pin	Name
1	IF Output	25	N/C
2	PLL Filter 1	26	V <sub>CC</sub> (DIG)
3	PLL Filter 2	27	REF 2
4	V <sub>EE</sub> (OSC)	28	REF 1
5	V <sub>CC</sub> (OSC)	29	V <sub>CC</sub> (RF)
6	V <sub>EE</sub> (OSC)	30	V <sub>EE</sub> (RF)
7	V <sub>EE</sub> (REG)	31	V <sub>EE</sub> (RF)
8	PRef	32	RF Input
9	PReset	33	V <sub>EE</sub> (RF)
10	V <sub>EE</sub> (IO)	34	V <sub>EE</sub> (RF)
11	CLK	35	V <sub>CC</sub> (RF)
12	N/C	36	N/C
13	N/C	37	O/P 1-
14	MAG	38	O/P 1+
15	SIGN	39	V <sub>CC</sub> (2)
16	OPCIK-	40	I/P 2-
17	OPCIK+	41	I/P 2+
18	V <sub>DD</sub> (IO)	42	V <sub>EE</sub> (IF)
19	PDN	43	V <sub>EE</sub> (IF)
20	TEST	44	O/P 2-
21	LD	45	O/P 2+
22	V <sub>EE</sub> (DIG)	46	V <sub>CC</sub> (3)
23	AGC -	47	I/P 3-
24	AGC +	48	I/P 3+

Fig. 1 Pin connections - top view

### RELATED PRODUCTS AND PUBLICATIONS

Part	Description	Data Reference
DW9255	35.42MHz SAW Filter	DS3861
GP2021	Twelve-Channel Correlator	DS4057
GP2010	GPS receiver RF Front-end	DS4056
GP2015	Design with the GP2015	AN4533
GPSBuilder-2	Twelve-Channel GPS receiver development system	DS4004
GPSBuilder-2.1	Twelve-Channel GPS development system	DS4537

## ABSOLUTE MAXIMUM RATINGS

### (Non-simultaneous)

Max. Supply Voltage	7V
Max. RF Input	+15dBm
Max. voltage on any pin except LD (pin 21) and PReset (pin 9), which are 5.5V	$V_{CC}/V_{DD} + 0.5V$
Min. voltage on any pin	$V_{EE} - 0.5V$
Storage Temperature	-65°C to +150°C
Operation Junction Temperature	-40°C to +150°C
10MHz Reference Input	1.5V pk -pk

## ESD PROTECTION

The GP2015 device is static sensitive. The most sensitive pins withstand a 750V test by the human body model. Therefore, ESD handling precautions are essential to avoid degradation of performance or permanent damage to this device.

## PRODUCT DESCRIPTION

The GP2015 receives the 1575.42MHz signal transmitted by GPS satellites and converts it to a 4.309MHz IF, using triple down-conversion. The 4.309MHz IF is sampled to produce a 2-bit digital output. If the GP2015 is used in conjunction with the GP2021 correlator, then the GP2021 provides a sampling clock of 5.714MHz. This converts the IF to a 1.405MHz 2-bit digital output at TTL levels.

The GP2015 can operate from a single supply from +3V (nominal) to +5V (nominal).

A block diagram of the circuit is shown in figure 2.

## IF STRIP

The input signal to the GP2015 is the GPS L1 signal received via an antenna and a suitable LNA. The L1 input is a spread spectrum signal at 1575.42MHz with 1.023Mbps BPSK modulation. The signal level at the antenna is about -130dBm, spread over a 2.046MHz bandwidth, so the wanted signal is actually buried in noise. The high RF input compression point of the GP2015 means that with subsequent IF filtering it is possible to reject large out of band jamming signals, in particular 900MHz as used by mobile telephones. The on-chip PLL generates the first local-oscillator frequency at 1400MHz. The output of the front-end mixer (Stage 1) at 175.42 MHz can then be filtered before being applied to the second stage. The double-balanced stage 1 mixer outputs are open-collectors, and require external dc bias to  $V_{CC}$ .

The second stage contains further gain and a mixer with a local oscillator signal at 140 MHz giving a second IF at 35.42 MHz. The second stage mixer is also double-balanced with open-collector outputs requiring external dc bias to  $V_{CC}$ .

The signal from stage 2 is passed through an external filter with a 1dB bandwidth of 1.9MHz. The performance of this filter is critical to system performance and it is recommended that a SAW filter is used (part number DW9255, also available from Mitel Semiconductor). The output of the filter then feeds the main IF amplifier. This includes 2 AGC amplifiers and a third mixer with a local oscillator signal at 31.111 MHz giving a final IF at 4.309 MHz. There is an on-chip filter after the third mixer which provides filtering centred on 4.309 MHz. The IF output, which has 1k output impedance, is provided for test purposes. All of the signals within the IF amplifier are differential including the filter inputs and outputs, except the IF output (pin 1), to reduce any common mode interference.

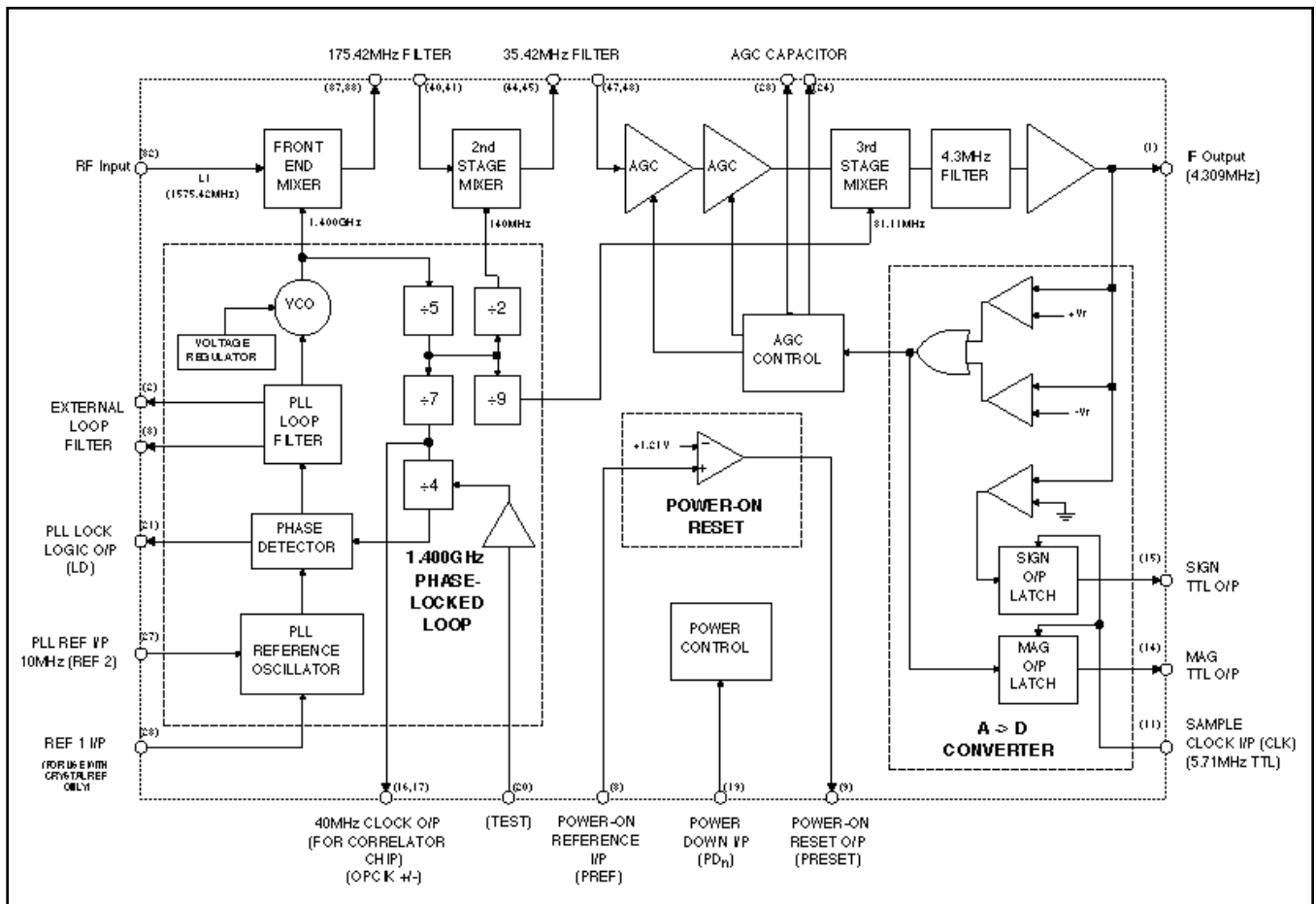

Fig. 2 Block diagram of GP2015

The IF output is fed to a 2-bit quantiser which provides sign and magnitude (MSB and LSB) outputs. The magnitude data controls the AGC loop, such that on average the magnitude bit is set (high) 30% of the time. The AGC time constant is set by an external capacitor.

The sign and magnitude data, SIGN (pin 15) and MAG (pin 14), are latched by the rising edge of the sample clock, CLK (pin 11), which is normally derived from the correlator; the GP2021 provides a 5.714MHz (=40/7) clock, giving a sampled IF centred on 1.405MHz.

The Digital Interface circuits use a separate power-supply,  $V_{DD}(IO)$ , which would normally be shared with the correlator to minimise crosstalk between the analog and digital sections of the device.

### ON-CHIP PHASE-LOCKED LOOP SYNTHESISER

All of the local oscillator signals are derived from an on chip phase locked loop synthesiser. This includes a 1400MHz VCO complete with on-chip tank circuit, dividers and phase detector, with external loop filter components. A 10.000MHz reference frequency is required for the PLL. This can be achieved by attaching an external 10.000MHz crystal to the on-chip PLL reference oscillator (see figure 5). However in most applications the user will need an external source, such as a TCXO, to provide greater frequency stability (see figure 6). An external reference should be ac coupled to REF2 (pin 27); REF 1 (pin 28) should be left open circuit.

The three local oscillator signals 1400MHz, 140.0MHz and 31.11MHz are derived from the 1400MHz synthesiser output. The synthesiser also provides a 40 MHz balanced differential output clock (pins 16 & 17) which can be used to clock the GP2021 correlator. The clock is a low level differential signal which helps minimise interference with the analog areas of the circuit. A PLL lock-detect output, LD (pin 21), is also provided, which is logic high when the PLL is phase-locked to the 10.000MHz reference signal.

The VCO power-supply incorporates an on-chip regulator to improve the noise-immunity of the PLL. This feature is only available when operating with a 5 volt (nominal) supply which is regulated to 3.3 volts internally. This internal regulated supply is referenced to  $V_{CC}(OSC)$  (pin 5). Figure 7 shows the required connections for both 3 volt and 5 volt operation.

A further feature of the circuit is the TEST input (pin 20). When this input is held high the PLL is unlocked with the VCO at its maximum frequency.

### POWER-DOWN CAPABILITY

A power down function is provided on the GP2015, to limit power consumption. This powers down the majority of the circuit except the "power-on reset" function (see below).

If the power down feature is not required, the Power-down input,  $PD_n$  (pin 19), should be connected to 0V dc (=Vee/Ground).

### POWER-ON RESET FUNCTION

The GP2015 includes a voltage detector which operates from the digital interface supply. This circuit is used to produce a TTL logic low output while the GPS receiver power supply is switching on, and produces a logic high output when the power supply voltage has achieved a nominal value. This output can be used to disable the GP2021 correlator while the power supply is switching on. An internal bandgap reference of approximately +1.21V is compared with the voltage on a sense pin, PRef (pin 8); when the voltage on this pin exceeds the reference, a TTL logic high level appears at the Power-on Reset output, PReset (pin 9). Thus, if the sense input voltage is derived from an external resistive divider from the Digital Interface supply,  $V_{DD}(IO)$  (pin 16), such that the sense voltage at nominal  $V_{CC}$  is  $V_S$ , then the supply threshold,  $V_{CC}(\text{thresh})$ , at which the PReset output goes to logic high is:-

$$V_S = \frac{V_{CC}(\text{nom}) \times 1.21}{V_{CC}(\text{thresh})}$$

For a  $V_{CC}(\text{nom})$  of 5.0V,  $V_{CC}(\text{thresh})$  may be set to approx. 4.0V, giving  $V_S$  of 1.5V.

For a  $V_{CC}(\text{nom})$  of 3.0V,  $V_{CC}(\text{thresh})$  may be set to approx. 2.4V, giving  $V_S$  of 1.5V.

### ADDITIONAL INFORMATION

All the digital inputs and outputs can use a separate power supply to help prevent digital switching transitions interacting with the analog sections of the device, and as an additional precaution, the digital inputs and outputs are on the opposite side of the device to the critical analog pins.

## ELECTRICAL CHARACTERISTICS

The Electrical Characteristics are guaranteed over the following range of operating conditions (see Fig. 3 for test circuit):

Industrial (I) grade:  $T_{AMB} = -40^{\circ}\text{C}$  to  $+85^{\circ}\text{C}$   
 Supply voltage:  $V_{CC}$  and  $V_{DD} = +2.7\text{V}$  to  $+5.5\text{V}$

**Test conditions (unless otherwise stated):**

Supply voltages:  $V_{CC} = +2.7\text{V}$  and  $+5.5\text{V}$ ,  $V_{DD} = +2.7\text{V}$  and  $+5.5\text{V}$   
 Test temperature: Industrial (I) grade product:  $+25^{\circ}\text{C}$

Characteristic	Value			Units	Conditions
	Min.	Typ.	Max.		
<b>SUPPLY CURRENT</b>					
<b>Normal mode</b> - Analog interface		55	77	mA	Pins 5, 26, 29, 35, 39, 46
- Digital interface		9	14.5	mA	Pin 18
<b>Power down mode</b> - Analog interface		3	6	mA	Pins 5, 26, 29, 35, 39, 46
- Digital interface		3	5	mA	Pin 18
Power Supply Differential			100	mV	Between any $V_{CC}/V_{DD}$ pins (Note 7)
Power down Response time		3		$\mu\text{s}$	(Note 7)
<b>IF STRIP</b>					
<b>Front End/Mixer 1</b>					
Conversion Gain (G1)	11	18	25	dB	$R_O = 600$ (Note 2) $F_{IN} = 1575.42\text{MHz}$ $Z_S = 50$ (Note 7)
Noise Figure		9		dB	
Input Compression (1dB)	-22	-16		dBm	
Input Impedance		17		nH	Pin 32 (Notes 1 and 7)
Differential Output Impedance		3.4		nH	(Notes 1 and 7)
		700		nH	Pins 37 & 38 (Note 8)
RF Input Image Rejection		7		dB	$F_{IN} = 1224.58\text{MHz}$ (Note 7)
<b>Stage 2/Mixer 2</b>					
Conversion Gain (G2)	22	27	33	dB	$F_{IN} = 175.42\text{MHz}$
Input Compression (1dB)	5	14		mV rms	
Differential Input Impedance		700		nH	Pins 40 & 41 (Note 8)
Differential Output Impedance		500		nH	Pins 44 & 45 (Note 8)
<b>Stage 3</b>					
High Gain (In terms of total strip)	106-G1-G2			dB	(Note 6)
High Gain (G3)		75		dB	$F_{IN} = 35.42\text{MHz}$
Gain Control Range		60		dB	(Note 3)
Differential Input Impedance		1		k	Pins 47 & 48 (Note 8)
IF Output amplitude	60	85	120	mV rms	CW input (Note 3)
IF Output impedance		1		k	Pin 1 (Note 8)
4.3MHz Filter Response					
Flatness $4.3 \pm 1\text{MHz}$	-1.5		+1.0	dB	
Rejection @ 0.5MHz		14		dB	(Note 7 and 9)
@ 50MHz	45	70		dB	
<b>2 BIT QUANTISER</b>					
Sign Duty Cycle	40	50	60	%	(Note 10)
Mag Duty Cycle	20	30	40	%	
AGC Time Constant		2		ms	$C_{AGC} = 100\text{nF}$
<b>ON-CHIP PLL SYNTHESISER</b>					
<b>Phase Noise</b>					
$\pm 1\text{kHz}$		-68		dBc/Hz	15kHz Loop Bandwidth
$\pm 10\text{kHz}$		-75		dBc/Hz	
$\pm 100\text{kHz}$		-88		dBc/Hz	(Note 7)
$\pm 1\text{MHz}$		-110		dBc/Hz	
$\pm 5\text{MHz}$		-120		dBc/Hz	
$\pm 50\text{MHz}$		-120		dBc/Hz	
PLL Spurs		-50		dBc	(Note 7)

Characteristic	Value			Units	Conditions
	Min.	Typ.	Max.		
VCO Maximum Lock Frequency	1414			MHz	
VCO Minimum Lock Frequency			1386	MHz	
VCO regulator output voltage	3	3.3	3.5	V	(Note 4)
VCO Gain	50	150	240	MHz/V	
Phase Detector Gain		5.3		V/rad	(Note 7)
10MHz Reference Input	0.1	0.6	1.2	V pk-pk	Pin 27
10MHz Reference Input Impedance		5		k	(Note 11)
PLL Lockup Time		6		ms	From Power up (Note 7)
PLL Loop Gain		150		dB	(Note 7)
<b>DIGITAL INTERFACES</b>					
<b>Sample Clock, Power Down, Test Inputs.</b>					Pins 11, 19, 20
V <sub>IH</sub>	2		V <sub>DD</sub>	V	
V <sub>IL</sub>	0		0.5	V	
Input Current High I <sub>IH</sub>			10	μA	V <sub>IH</sub> = V <sub>DD</sub>
Input Current Low I <sub>IL</sub>	-300			μA	V <sub>IL</sub> = V <sub>EE</sub>
<b>Sign/Mag Outputs</b>					Pins 15, 14
V <sub>OH</sub>	V <sub>DD</sub> -1			V	I <sub>O</sub> = -0.5mA
V <sub>OL</sub>			0.5	V	I <sub>O</sub> = 0.5mA
Sample Clock to Sign/Mag Delay		20		ns	CL = 15pF, RL = 15k (Note 7)
<b>40MHz Clock Output</b>					
High Level (V <sub>OH</sub> )	V <sub>DD</sub> -1.25	V <sub>DD</sub> -1	V <sub>DD</sub> -0.8	V	Pins 16 & 17
Low Level (V <sub>OL</sub> )		V <sub>OH</sub> -0.1		V	(Note 5)
Output (differential)		220		mV p-p	CL = 15pF (GND) (Note 7)
					CL = 5pF (Diff) (Note 7)
Duty Cycle		43		%	(Note 7)
<b>LD (PLL Lock)/PReset Outputs</b>					Pins 21 and 9
Low Level (V <sub>OL</sub> )		0.2	0.5	V	I <sub>O</sub> = 0.5mA
High Level (V <sub>OH</sub> )	V <sub>DD</sub> -1	V <sub>DD</sub>		V	I <sub>O</sub> = -10μA
<b>Power-on Reset comparator input</b>					Pin 8
Power Reset Reference Level	1.1		1.35	V	
Power Reset Reference Input Current	-10		10	μA	

**Notes On Electrical Characteristics:-** All RF measurements are made with appropriate matching to the input or output impedances, such as balun transformers, and levels refer to matched 50ohm ports (see figure 3 for test circuit)

1. RF input impedance (series) without input matching components connected - expressed as Real impedance with reactive inductor value. Measured at 1575.42MHz.
2. Input matched to 50ohm, output loaded with 600ohm differential
3. Maximum Stage 3 input signal amplitude for correct AGC operation = 20mV rms.
4. VCO regulator voltage measured with respect to V<sub>cc</sub> (OSC) - pin 5.
5. The OPCLK outputs are differential and are referenced to V<sub>DD</sub>.
6. Minimum gain requirement expressions:

$$-7\text{dBm} < -174\text{dBm/Hz} + 19\text{dB} + G1 + G2 + G3 - 21\text{dB} + 63\text{dB}$$

where -7dBm = typical IF Output level with AGC active (equivalent to 100mV rms)

- 174dBm/Hz = background noise level at RF input
- 19dB = sum of LNA gain and noise figure
- 21dB = total loss in 175MHz and 35MHz filters
- 63dB = summation of noise over a 2MHz bandwidth

Rearranging the above expression gives  $G1 + G2 + G3 > 106\text{dB}$ .

7. This parameter is not production tested.
8. This impedance is tolerated at +/-30% and is not production tested.
9. Roll off occurs in on-chip capacitive coupling IF Output to input of ADC circuit. Not measurable at IF Output.
10. CW input on pins 47 & 48 of 35.42MHz at 7mV rms.
11. This input impedance applies to the typical input level. The impedance is level dependent and is not tested or guaranteed.

## PIN DESCRIPTIONS

All  $V_{EE}$  and  $V_{CC}/V_{DD}$  pins must be connected to ensure correct operation

Pin No.	Signal Name	Input/Output	Description
1	IFOutput	Output	IF Test output. Connected to output of Stage 3 prior to the A to D converter. A series 1k resistor is incorporated for buffering purposes.
2	PLL Filter 1	Output	PLL Filter 1. Connected to the bias network within the on-chip VCO. An external PLL loop filter network should be connected between this pin and PLL Filt 2 (see below).
3	PLL Filter 2	Output	PLL Filter 2. Connected to the varactor diodes within the on-chip VCO. An external PLL loop filter network should be connected between this pin and PLL Filt 1 (see above).
4,6	$V_{EE}$ (OSC)	Input	Negative supply to the on-chip VCO. (See Note 1)
5	$V_{CC}$ (OSC)	Input	Positive supply to the on-chip VCO.
7	$V_{EE}$ (REG)	Input	Negative supply to the VCO regulator. This must be connected to GND.
8	PRef	Input	Power-on Reset Reference input. An on-chip comparator produces a logic HI when the PRef input voltage exceeds +1.21V. (Nom) (See Page 3)
9	PReset	Output	Power-on Reset Output. A TTL compatible output controlled by the Power-on reset comparator (See above). This output remains active even when the chip is powered down. (See pin 19 - PDn).
10	$V_{EE}$ (IO)	Input	Negative supply to the Digital Interface. (See Note 2)
11	CLK	Input	Sample Clock input from the correlator chip. A TTL compatible input (which operates at 5.714MHz if used with GP2021 correlator device) used to clock the MAG & SIGN output latches, on the <b>rising</b> edge of the CLK signal.
12, 13	N/C		Not connected. (See Note 4)
14	MAG	Output	Magnitude bit data output. A TTL compatible signal, representing the <i>magnitude</i> of the mixed down IF signal. Derived from the on-chip 2-bit A to D converter, synchronised to the CLK input clock signal.
15	SIGN	Output	Sign bit data output. A TTL compatible signal, representing the <i>polarity</i> of the mixed down IF signal. Derived from the on-chip 2-bit A to D converter, synchronised to the CLK input clock signal.
16	OPClk-	Output	40MHz Clock output - inverse phase. One side of a balanced differential output clock, with opposite polarity to Pin 17 - OPClk+. Used to drive a master-clock signal within the correlator chip.
17	OPClk+	Output	40MHz Clock output - true phase. Other side of a balanced differential output clock set, with opposite polarity to Pin 16 - OPClk-. Used to drive a master-clock signal within the correlator chip.

Pin No.	Signal Name	Input/Output	Description
18	V <sub>DD</sub> (IO)	Input	Positive supply to the Digital Interface. (See Note 2)
19	PDn	Input	Power-Down control input. A TTL compatible input, which when set to logic high, will disable ALL of the GP2015 functions, except the power-on reset block. Useful to reduce the total power consumption of the GP2015. If this feature is not required, the pin should be connected to 0V (V <sub>EE</sub> /GND).
20	TEST	Input	Test control input - Disable PLL. A TTL compatible input, which when set to logic high, will disable the on-chip PLL, by disconnecting the divided-down VCO signal to the phase-detector. The VCO will free run at its upper range of frequency operation. If this feature is not required, the pin should be connected to 0V (V <sub>EE</sub> /GND).
21	LD	Output	PLL Lock Detect output. A TTL compatible output, which indicates if the PLL is phase-locked to the PLL reference oscillator. Will become logic high only when phase-lock is achieved.
22	V <sub>EE</sub> (DIG)	Input	Negative supply to the PLL and A to D converter.
23	AGC-	Output	AGC Capacitor output - inverse phase. One side of a balanced output from the AGC block within IF Stage 3, to which an external capacitor is connected to set the AGC time-constant.
24	AGC+	Output	AGC Capacitor output - true phase. One side of a balanced output from the AGC block within IF Stage 3, to which an external capacitor is connected to set the AGC time-constant.
25	N/C		Not connected. (See Note 4)
26	V <sub>CC</sub> (DIG)	Input	Positive supply to the PLL and A to D converter.
27	REF 2	Input	10.000MHz PLL Reference signal input . Input to which an externally generated 10.000MHz PLL reference signal should be ac coupled, if an external PLL reference frequency source (e.g TCXO) is used (see fig. 6). If no external reference is used, this pin forms part of the on-chip PLL reference oscillator, in conjunction with an external 10.000MHz crystal (see fig. 5).
28	REF 1	Input	PLL reference oscillator auxillary connection. Used in conjunction with Pin 27 (REF 2) to allow a 10.000MHz external crystal to provide the PLL reference signal if no external PLL reference frequency source (e.g TCXO) is used. This pin should NOT be connected if an external TCXO is being used (see fig. 5).
29, 35	V <sub>CC</sub> (RF)	Input	Positive supply to the RF input and Stage 1 IF mixer. Both pins are connected internally, but must both be connected to V <sub>CC</sub> externally, to keep series inductance to a minimum.
30, 31, 33, 34	V <sub>EE</sub> (RF)	Input	Negative supply to the RF input and Stage 1 IF mixer. The pins are all connected internally, but must ALL be connected to 0V (V <sub>EE</sub> /GND) externally, to keep series inductance to a minimum.

Pin No.	Signal Name	Input/Output	Description
32	RF Input	Input	RF input. The GPS RF input signal @ 1575.42MHz from an external antenna with LNA and filter is connected to this pin via an input-matching network (see fig.4).
36	N/C		Not connected. (See Note 4)
37	O/P 1-	Output	Stage 1 mixer output @ 175.42MHz - inverse phase. One of a balanced output from first stage IF mixer, to which one input of an external balanced 175MHz bandpass filter is connected. External dc biasing is required via an inductor connected to $V_{CC}(RF)$ - the value of which is dependent on the filter used.
38	O/P 1+	Output	Stage 1 mixer output @ 175.42MHz - true phase. Second of a balanced output from first stage IF mixer, to which the second input of an external balanced 175MHz bandpass filter is connected. External dc biasing is required via an inductor connected to $V_{CC}(RF)$ - the value of which is dependent on the filter used.
39	$V_{CC}(2)$	Input	Positive supply to the Stage 2 IF mixer.
40	I/P 2-	Input	Stage 2 mixer input @ 175.42MHz - inverse phase. One of a balanced input to the second stage IF mixer, to which one of the balanced signal outputs from the external 175MHz bandpass filter is connected.
41	I/P 2+	Input	Stage 2 mixer input @ 175.42MHz - true phase. Second of a balanced input to the second stage IF mixer, to which the second of the balanced signal outputs from the external 175MHz bandpass filter is connected.
42, 43	$V_{EE}(IF)$	Input	Negative supply to the Stage 2 IF mixer, and Stage 3 IF block.
44	O/P 2-	Output	Stage 2 mixer output @ 35.42MHz - inverse phase. One of a balanced output from second stage IF mixer, to which one input of an external balanced 35.42MHz bandpass filter is connected. External dc biasing is required via an Inductor connected to $V_{CC}$ . (See Note 3)
45	O/P 2+	Output	Stage 2 mixer output @ 35.42MHz - true phase. Second of a balanced output from second stage IF mixer, to which the second input of an external balanced 35.42MHz bandpass filter is connected. External dc biasing is required via an Inductor connected to $V_{CC}$ . (See Note 3)
46	$V_{CC}(3)$	Input	Positive supply to the Stage 3 IF mixer.
47	I/P 3-	Input	Stage 3 mixer input @ 35.42MHz - inverse phase. One of a balanced input to the third stage IF mixer, to which one of the balanced signal outputs from the external 35.42MHz bandpass filter is connected. (See Note 3)
48	I/P 3+	Input	Stage 3 mixer input @ 35.42MHz - true phase. Second of a balanced input to the third stage IF mixer, to which the second of the balanced signal outputs from the external 35.42MHz bandpass filter is connected. (See Note 3)



### Notes on Pin Descriptions

- Both pins 4 & 6 ( $V_{EE}$  (OSC)) are connected internally. If the VCO regulator is used ( $V_{CC} = +5.00V$  nominal) then both pins 4 & 6 must be left floating, with either pin de-coupled to  $V_{CC}$  (OSC) with a 100nF capacitor. In this configuration, the dc output level of the regulator can be monitored from  $V_{EE}$  (OSC), with respect to  $V_{CC}$  (OSC) - NOT 0V ( $V_{EE}/GND$ ). For operation at  $V_{CC} < +4.0V$ , the VCO regulator cannot be used, and both  $V_{EE}$  (OSC) pins must be shorted to  $V_{EE}$  (REG) (Pin 7) - see Fig. 7.
- The Digital Interface supply is independent from all the other supply pins, allowing supply separation to reduce the likelihood of undesirable digital signals interfering with the IF strip. (Note the maximum allowable Power Supply Differential in the Electrical Characteristics - page 4).
- The 35.42MHz Bandpass filter should have a bandwidth of approx 2.0MHz. Ideally, this should be a DW9255 SAW filter.
- These pins are not connected within the package, and may therefore be used in power/ground routing if desired. To avoid crosstalk, their use in signal routing is not recommended.

### CONTROL SIGNALS

	L	H
Power Down	Normal Operation	Powered Down
TEST	Normal Operation	Test

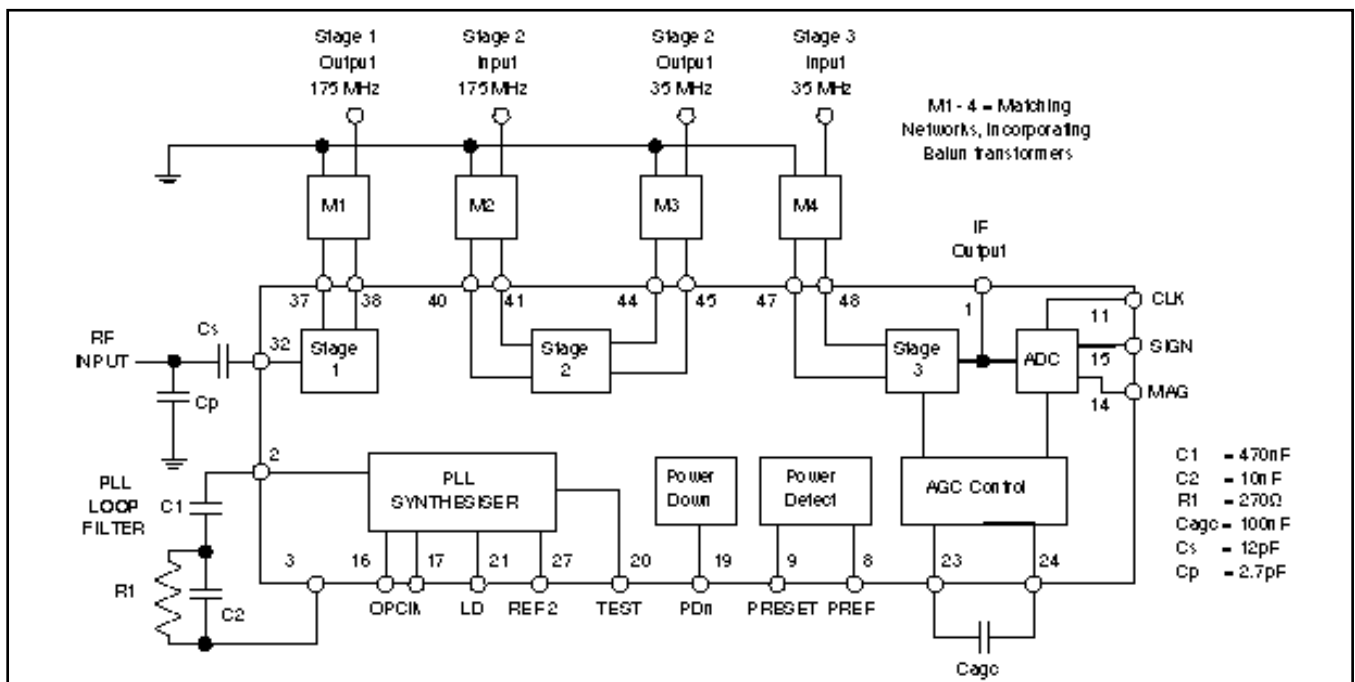

Fig. 3 GP2015 test circuit

### OPERATING NOTES

A typical application circuit is shown in figure 4 with the GP2015 front-end interfaced to the GP2021 12-channel correlator integrated circuit. The RF input has an unmatched input impedance (see page 4). The RF input matching components  $C_s$  and  $C_p$  should be mounted as close to the RF input as possible: also the Vee(RF) tracks must be kept as short as possible. A SAW filter may be used as a 175.42MHz filter, but this can be replaced by a simpler coupled-tuned LC filter if there is no critical out-of-band jamming immunity requirement. The DC bias to mixer 1 is provided via inductors L1 and L2, which may form part of the 175.42MHz filter. The output of mixer 2 requires an external dc bias, achieved with inductors L3 and L4, which also serve to tune out the input capacitance of the DW9255 SAW filter. The output of the SAW filter is tuned with inductor L5. Capacitor ( $C_{agc}$ ) determines the AGC time-constant. The PLL loop filter components are selected to give a PLL loop bandwidth of approximately 10kHz. The IF Output is normally used for test-purposes only, but is available to the user if required. Typically a low noise preamplifier (gain  $> +15dB$ ) is used between the

antenna and the RF input (pin 32), and may be located remotely, with the antenna.

### QUALITY AND RELIABILITY

At Mitel Semiconductor, quality and reliability are built into products by rigorous control of all processing operations, and by minimising random, uncontrolled effects in all manufacturing operations. Process management involves full documentation of procedures, recording of batch-by-batch data, and the use of traceability procedures.

A common information management system is used to monitor the manufacturing on Mitel Semiconductor CMOS and Bipolar processes. All products benefit from the use of an integrated monitoring system throughout all manufacturing operations, leading to high quality standards for all technologies.

Further information is contained in the Quality Brochure, available from Mitel Semiconductor's Sales Offices.

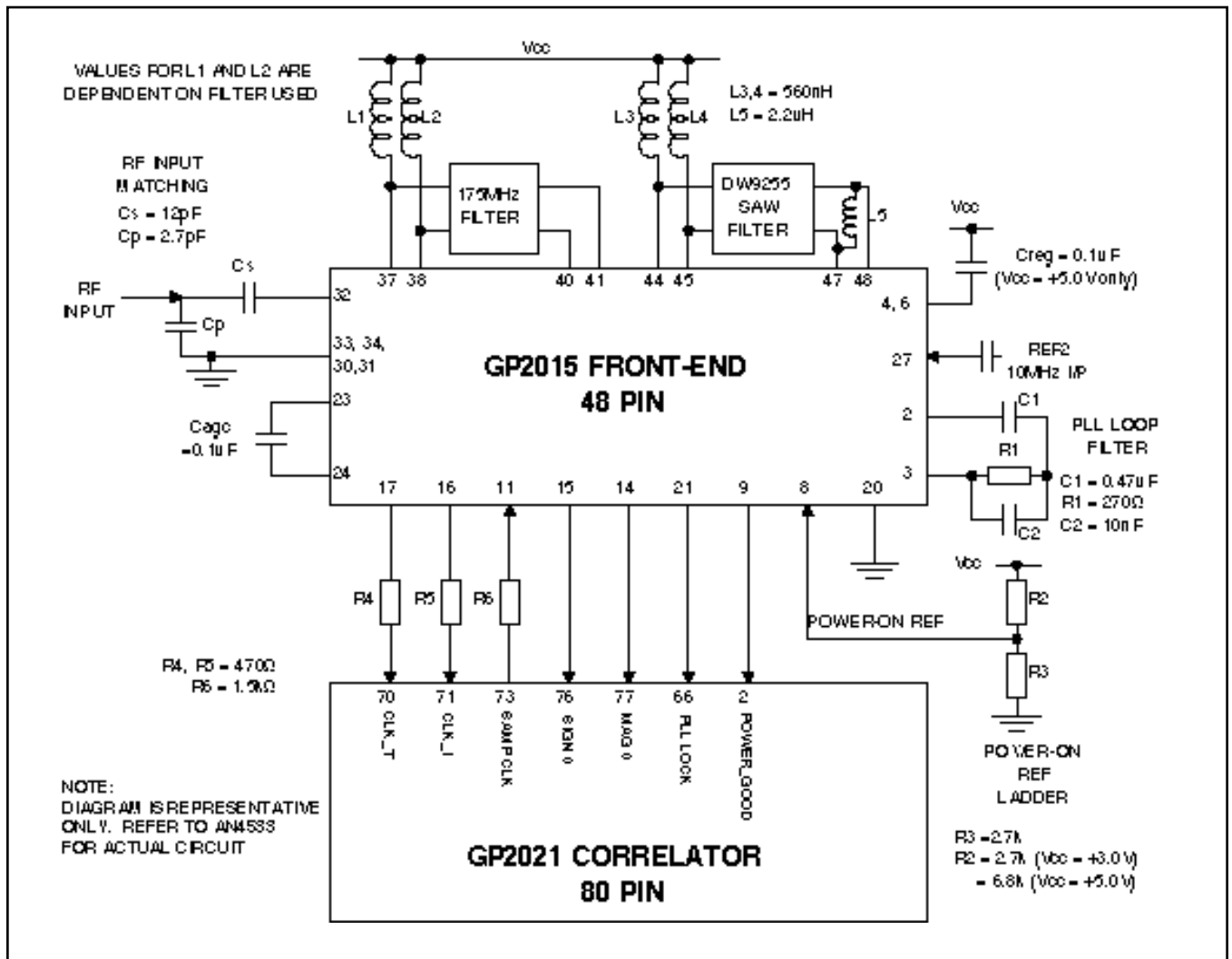

Fig. 4 GP2015 typical application

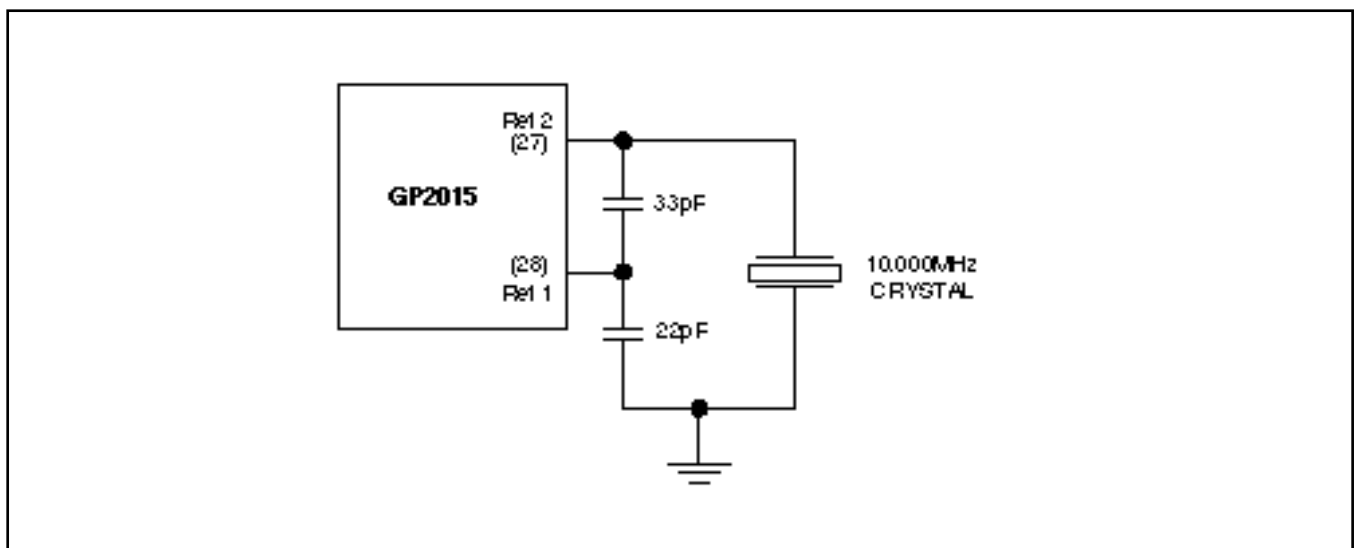

Fig. 5 Crystal Reference connections

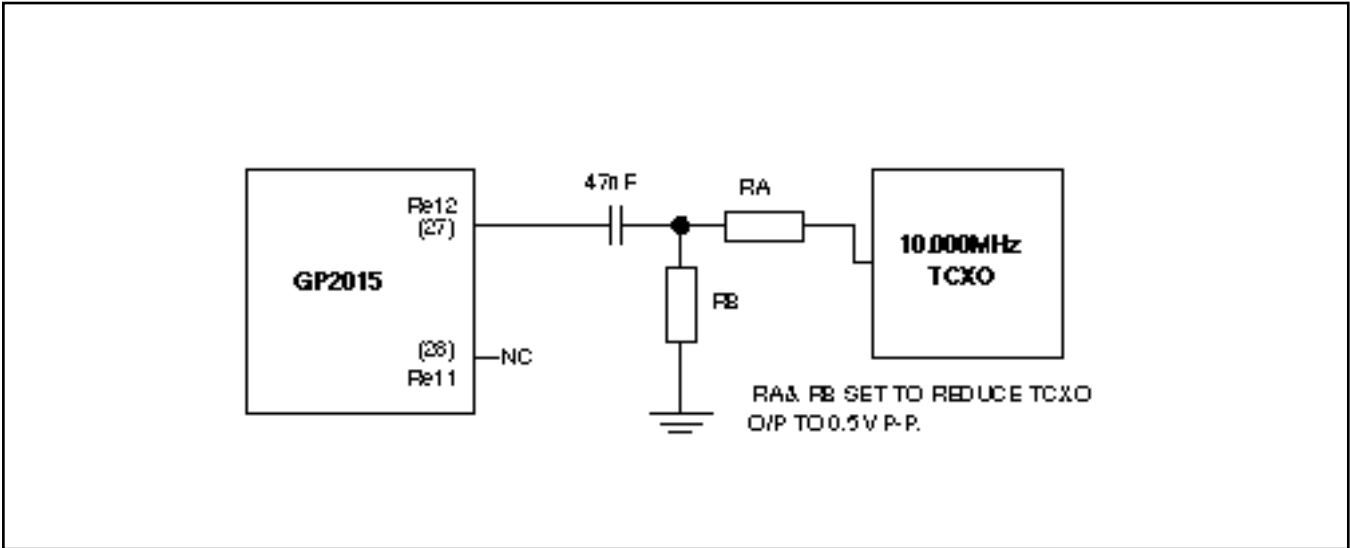

Fig. 6 TCXO Reference connections

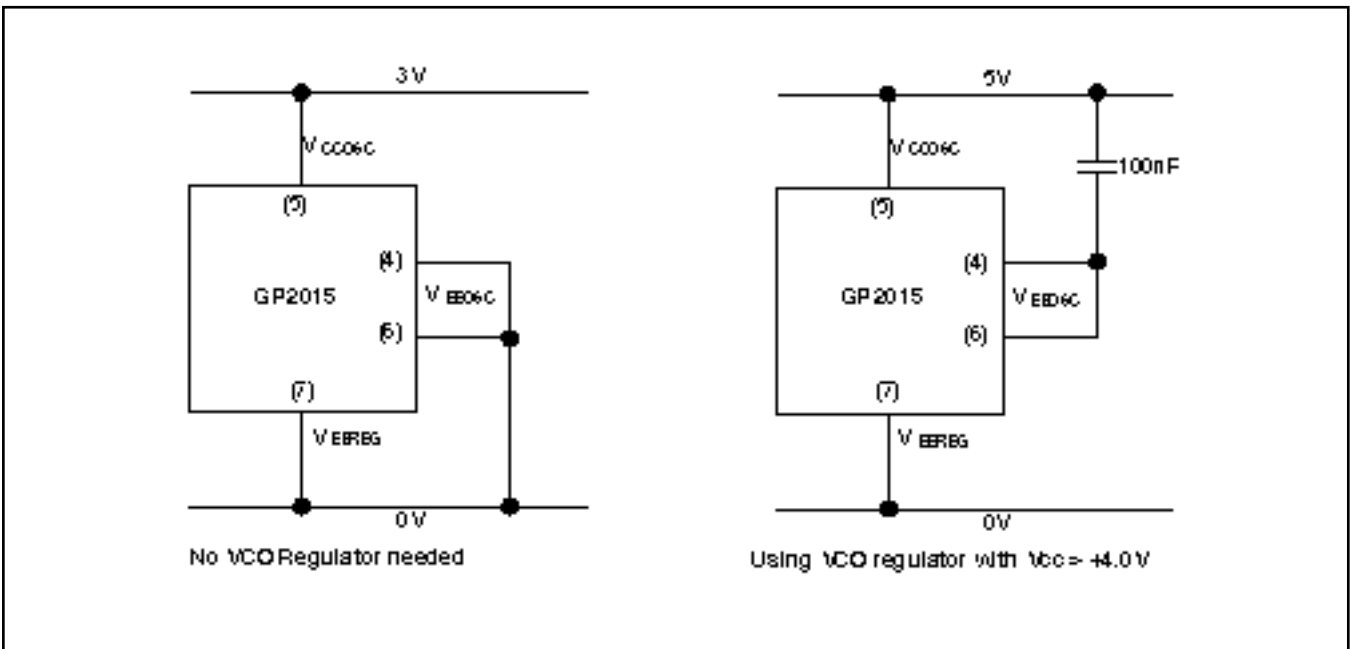

Fig. 7 VCO power-supply connections

## TYPICAL CHARACTERISTICS OF THE GP2015 GPS RECEIVER RF FRONT-END

The GP2015 has been characterised to guarantee reliable operation over the Industrial Temperature range (-40°C -> +85°C ambient). This was achieved by setting the device case temperature to extremes of +110°C and -50°C. The following charts show the typical variation of key parameters across the extended case temperature range.

*NOTE:- ALL Measurements at Vcc = +2.65V made with VCO voltage-regulator DISABLED.*

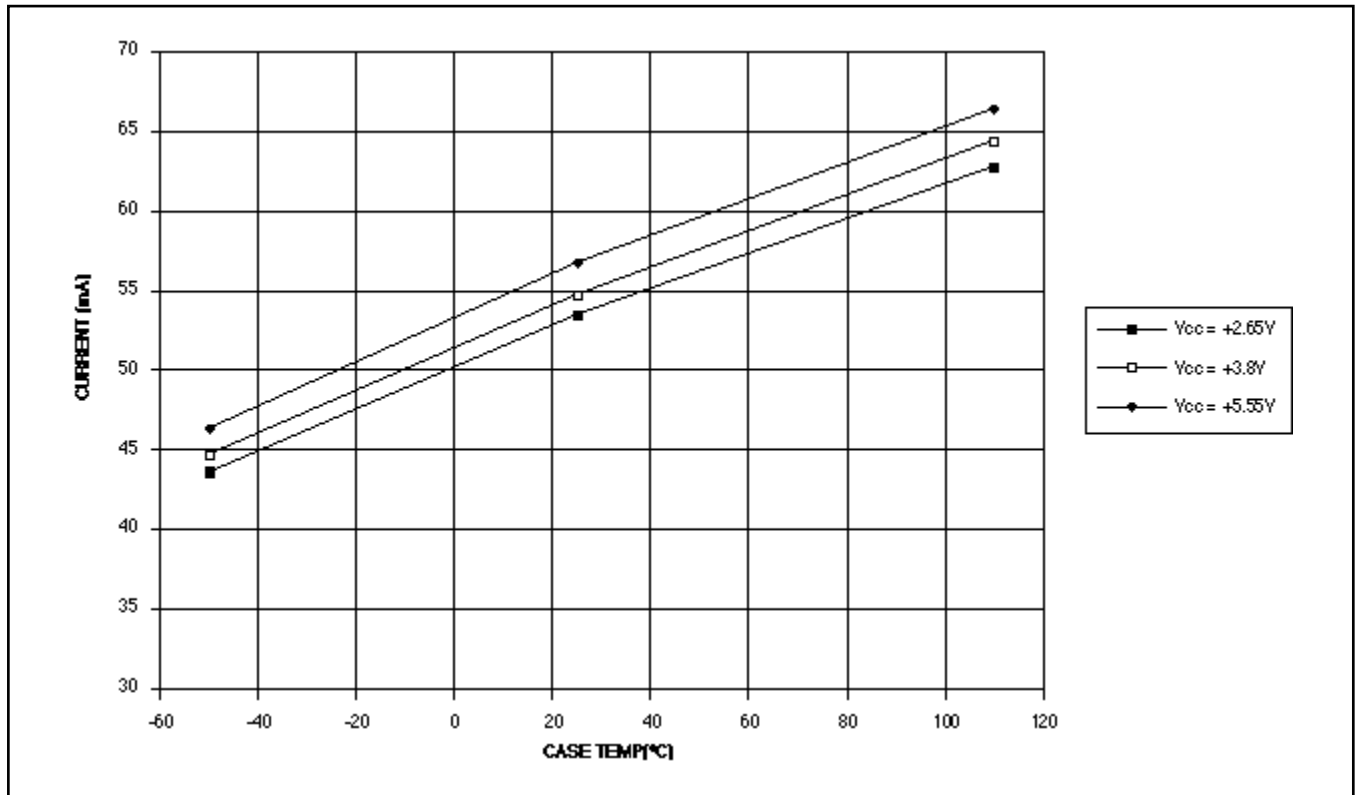

Fig. 8 Supply Current - Analog interface - normal mode

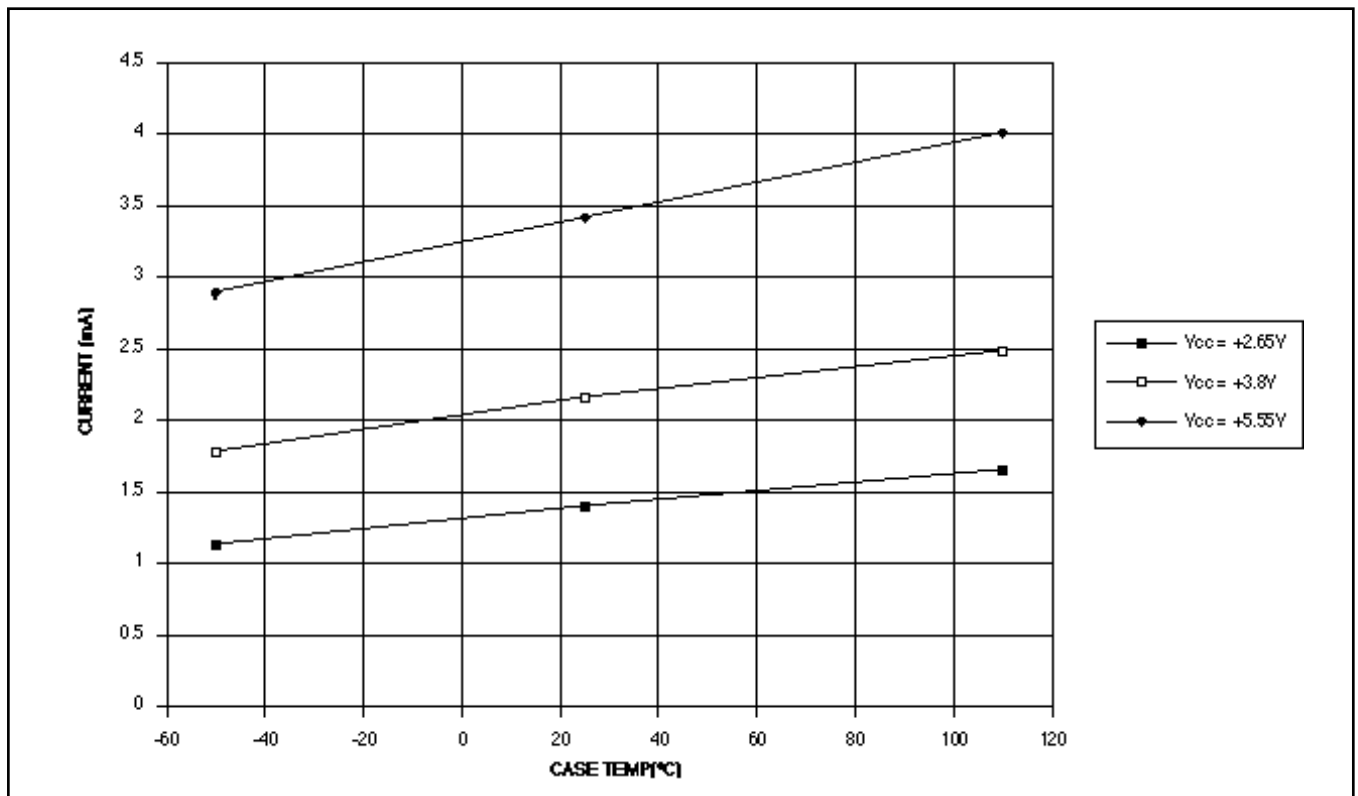

Fig. 9 Supply Current - Analog interface - power-down mode

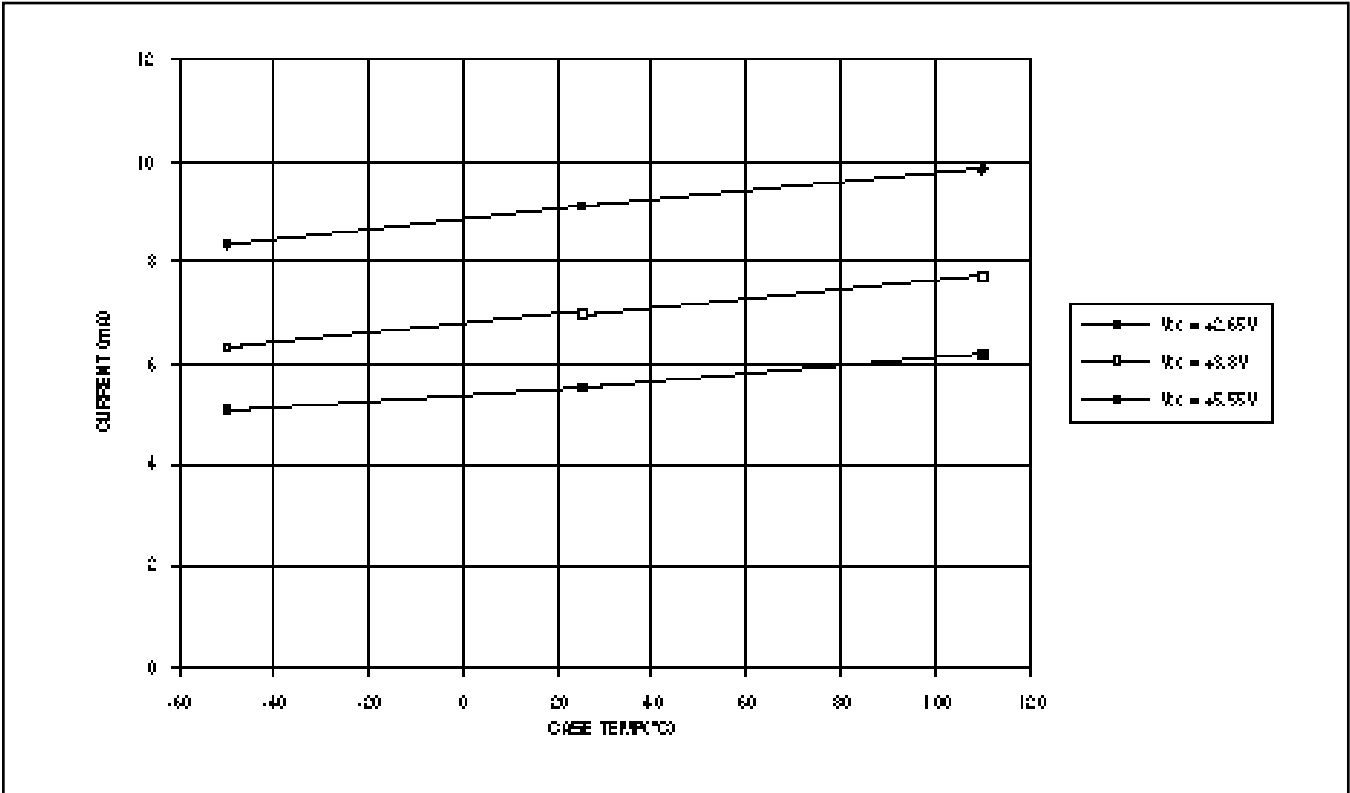

Fig. 10 Supply Current - Digital interface - normal mode

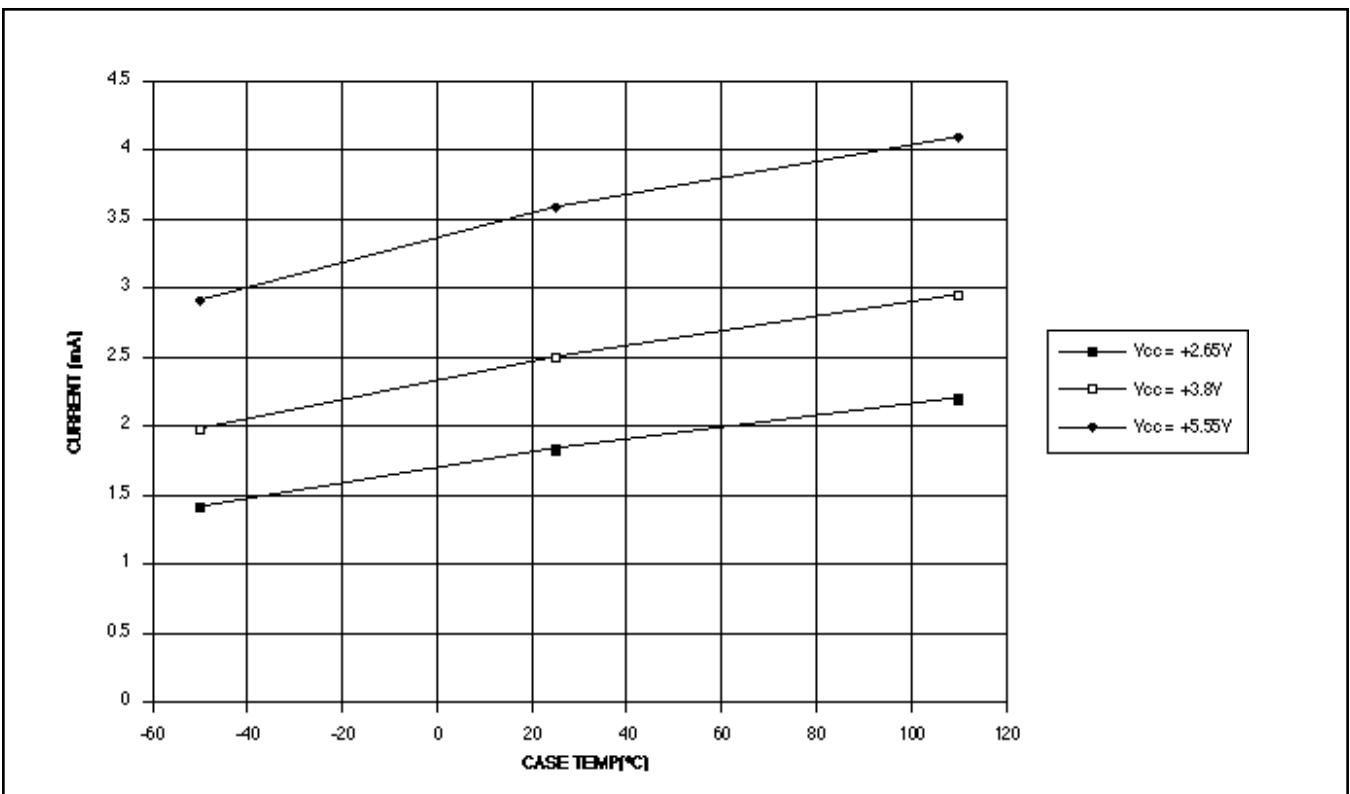

Fig. 11 Supply Current - Digital interface - power-down mode

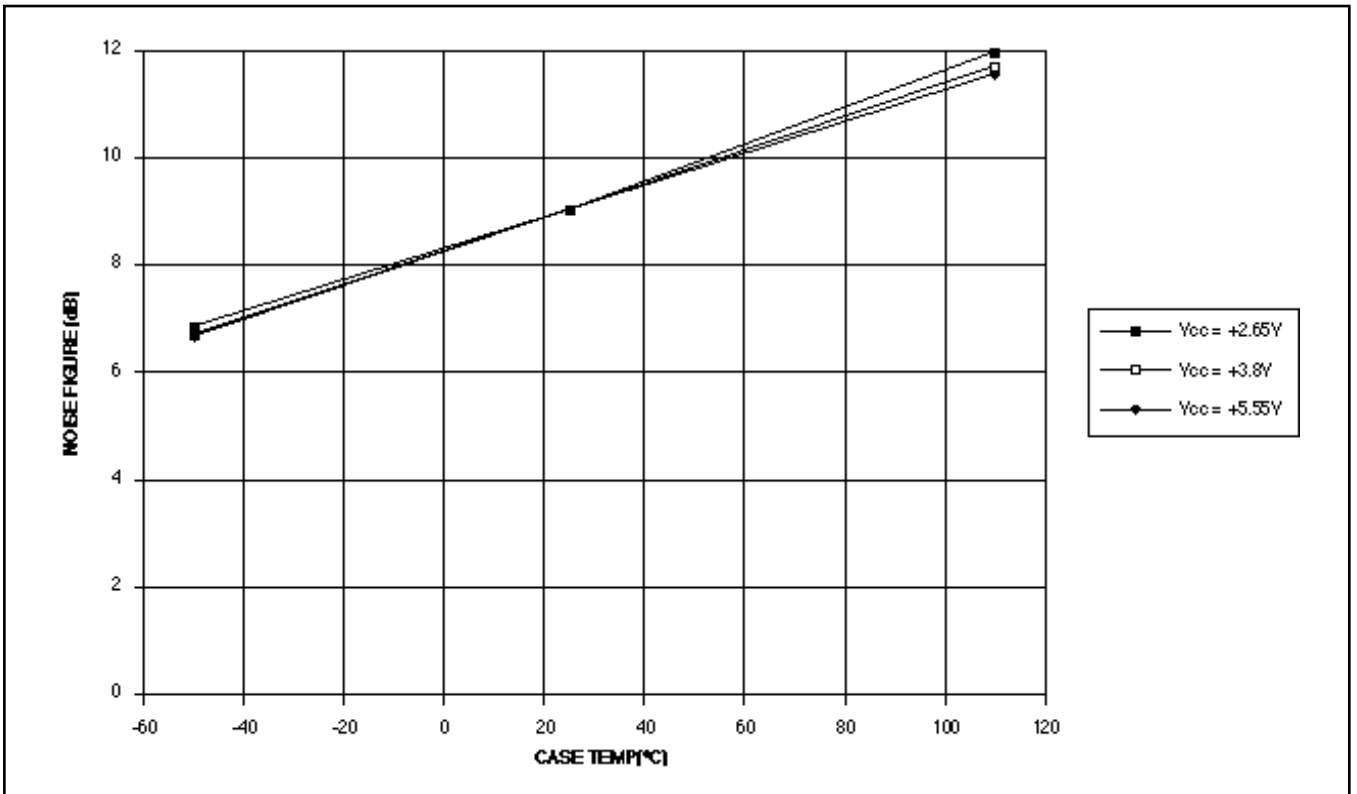

Fig. 12 Noise figure of IF chain in a typical application circuit

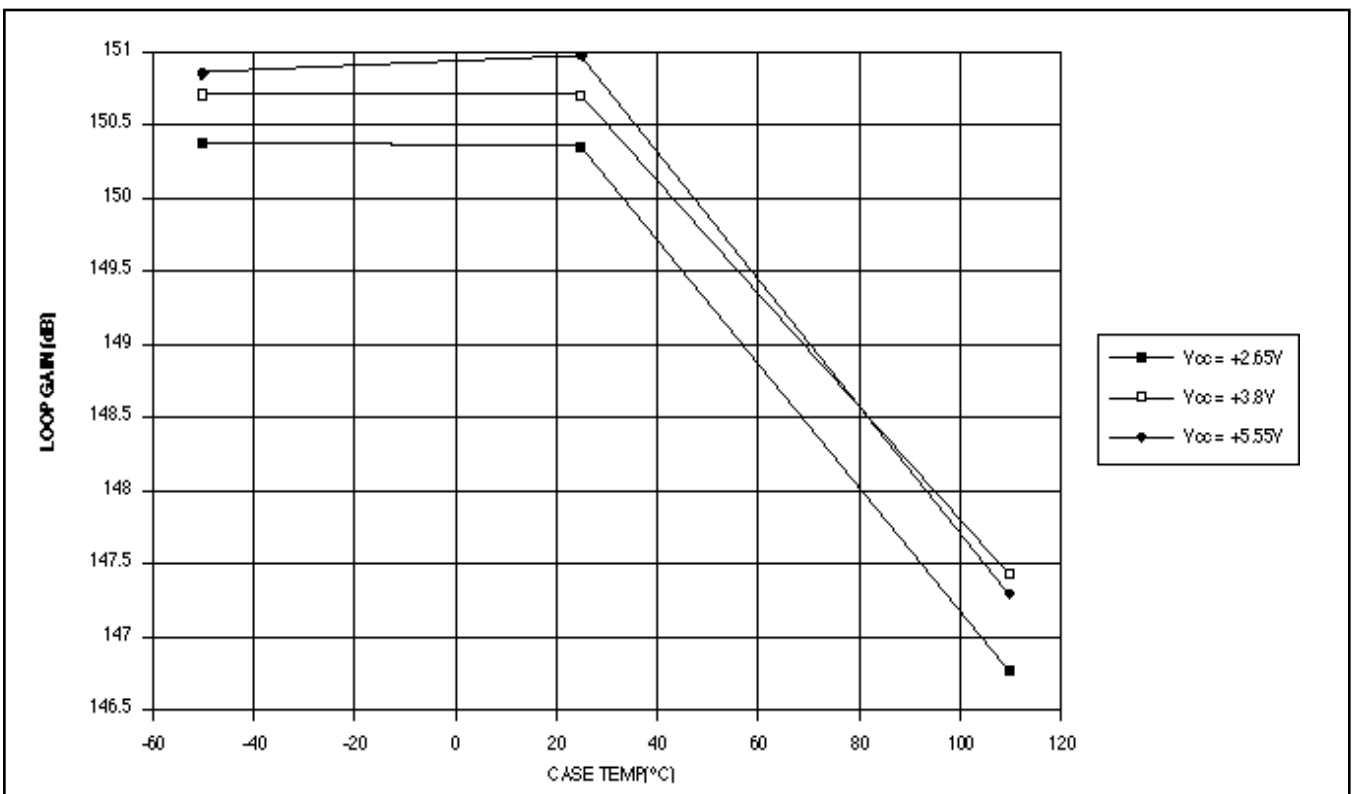

Fig. 13 On-chip Phase-locked-loop Synthesiser Loop gain

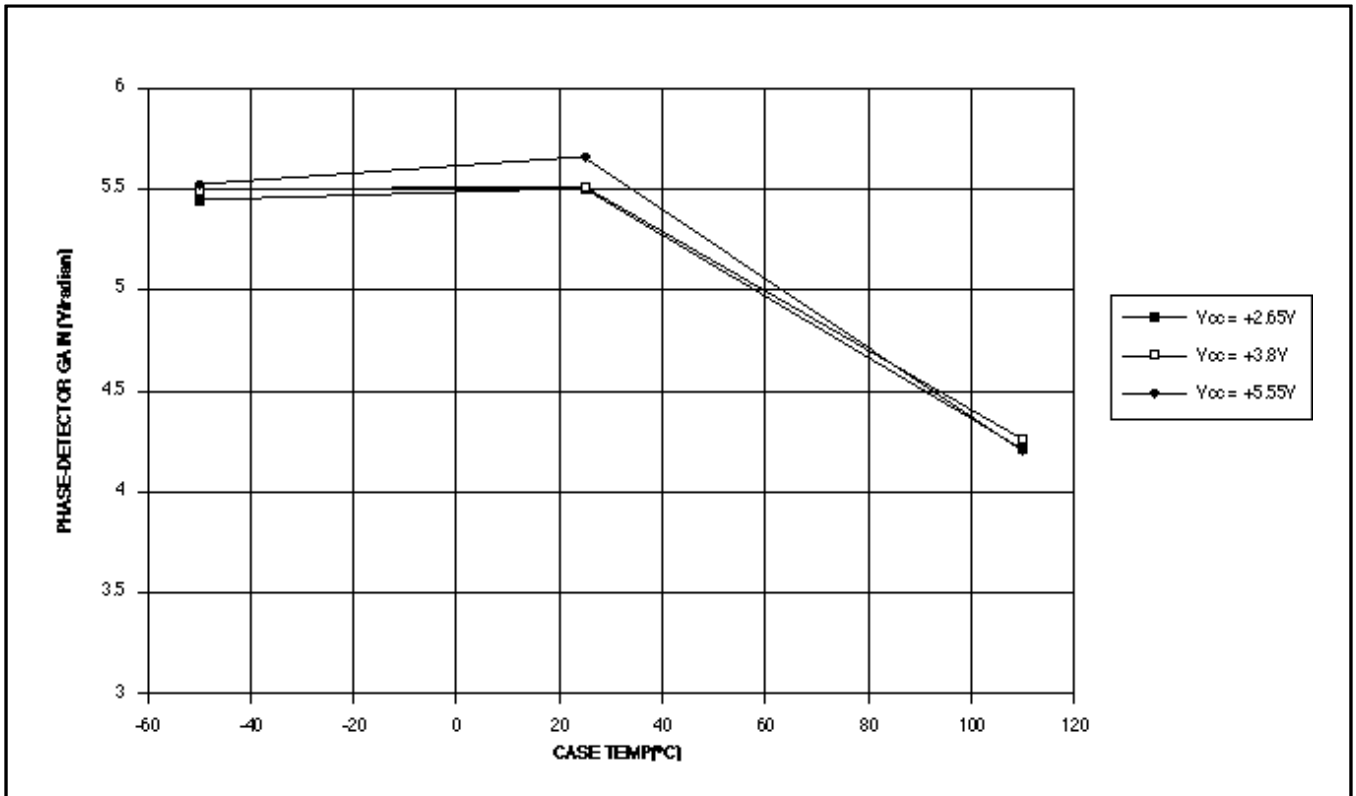

Fig. 14 On-chip Phase-locked-loop Synthesiser Phase-detector gain

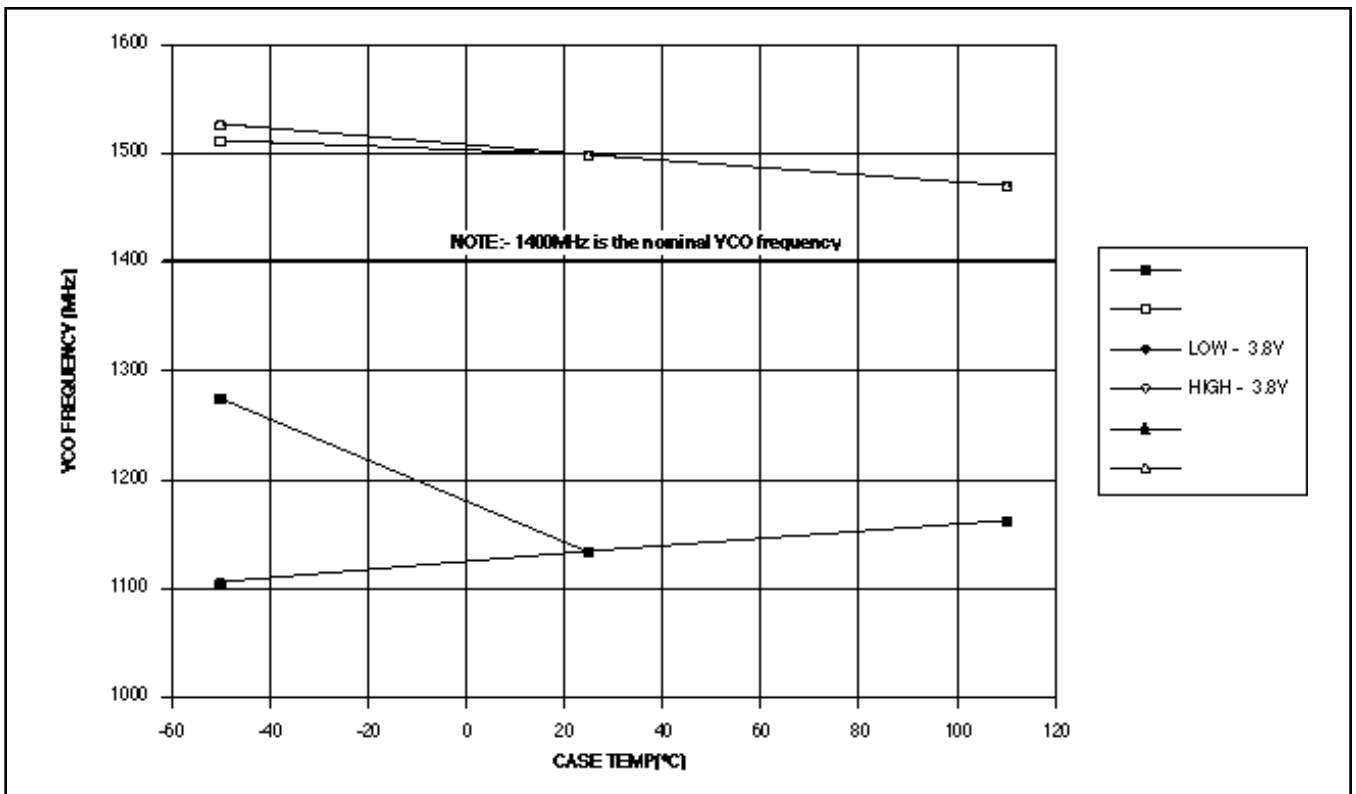

Fig. 15 On-chip Phase-locked-loop Synthesiser - LOW and HIGH limits of VCO frequency for PLL to be locked  
(Note that this a **typical** characteristic and **cannot** be guaranteed)

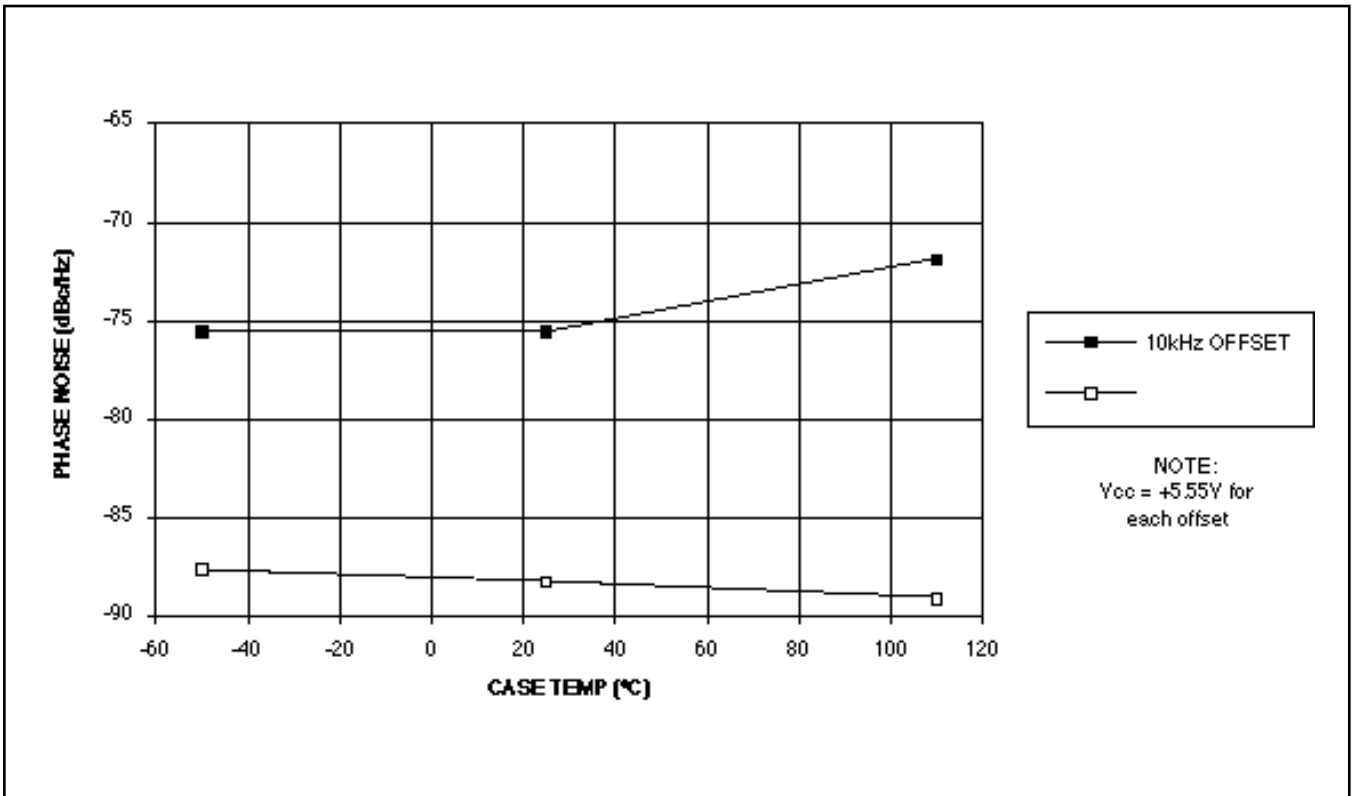

Fig. 16 On-chip Phase-locked-loop Synthesiser - Phase-noise of VCO producing 1400MHz CW signal at 10kHz offset (15kHz PLL loop bandwidth)

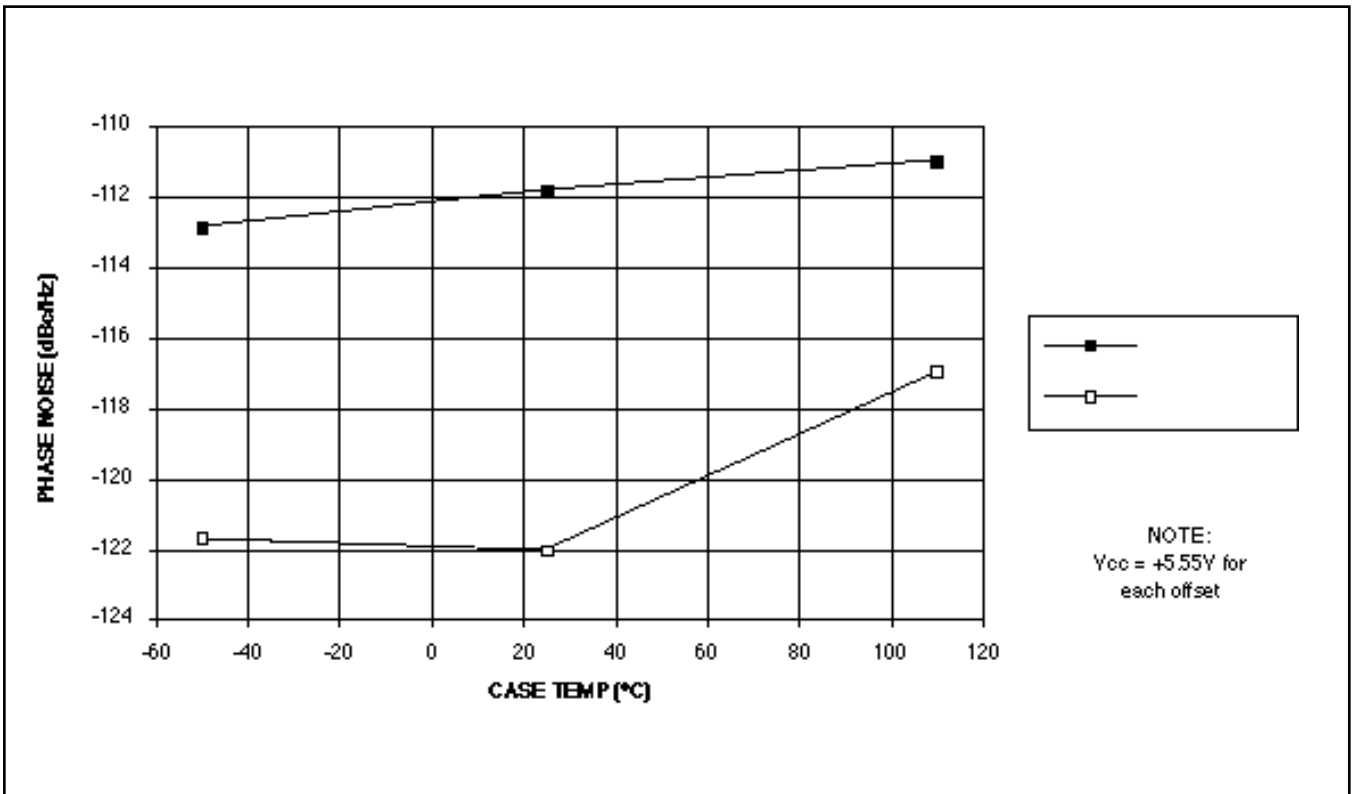

Fig. 17 On-chip Phase-locked-loop Synthesiser - Phase-noise of VCO producing 1400MHz CW signal at 100kHz offset (15kHz PLL loop bandwidth)



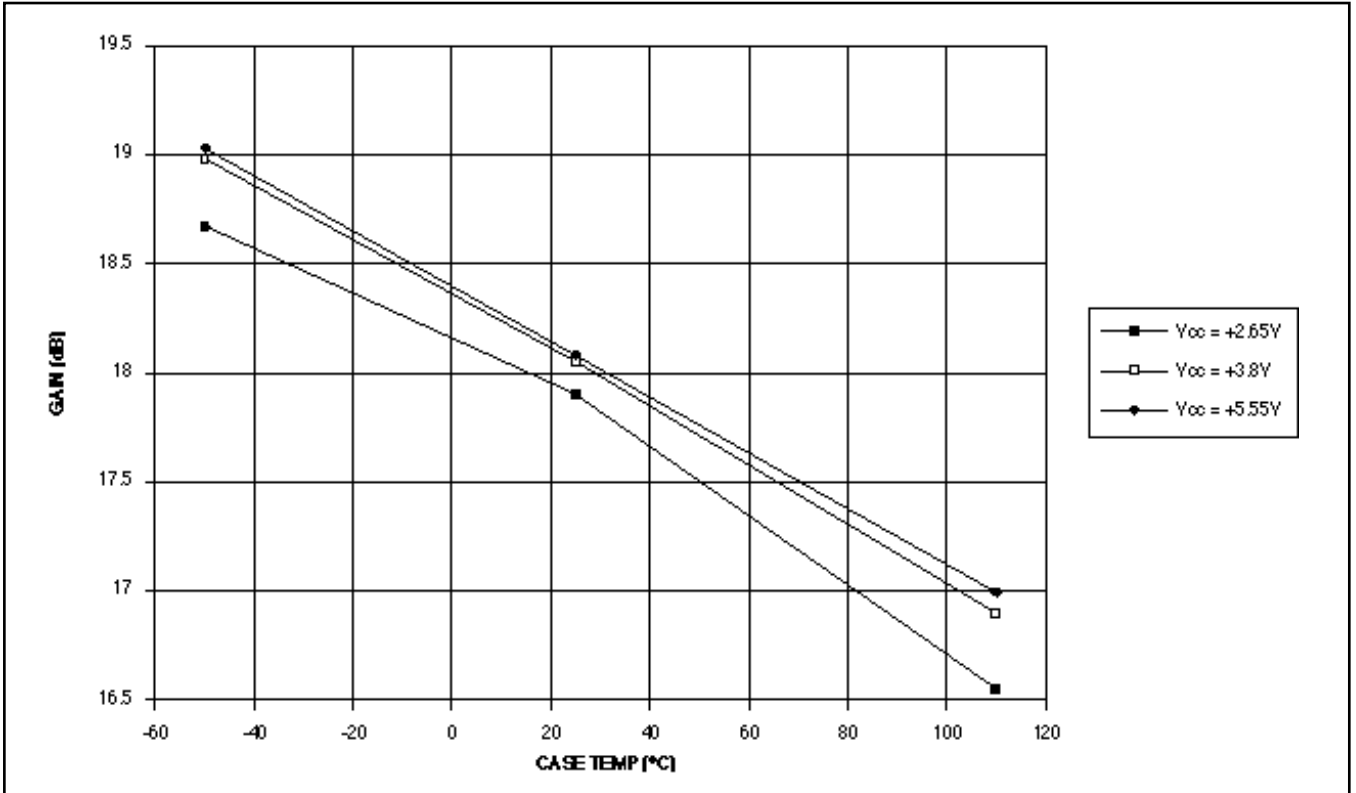

Fig. 18 Frontend/Mixer 1 Small-signal Conversion Gain - RF I/P frequency at 1575.42MHz

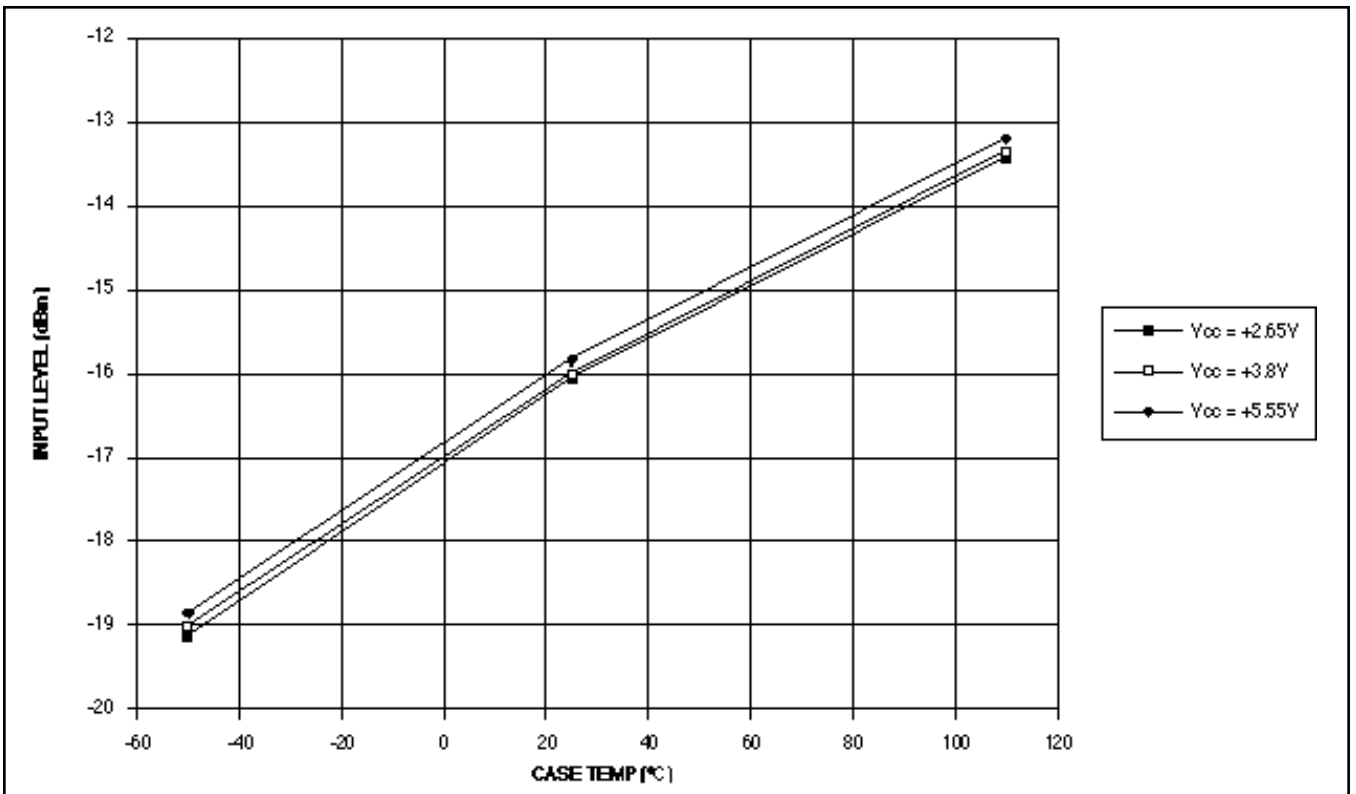

Fig. 19 Frontend/Mixer 1 Input level for 1dB Conversion Gain-compression - RF I/P frequency at 1575.42MHz

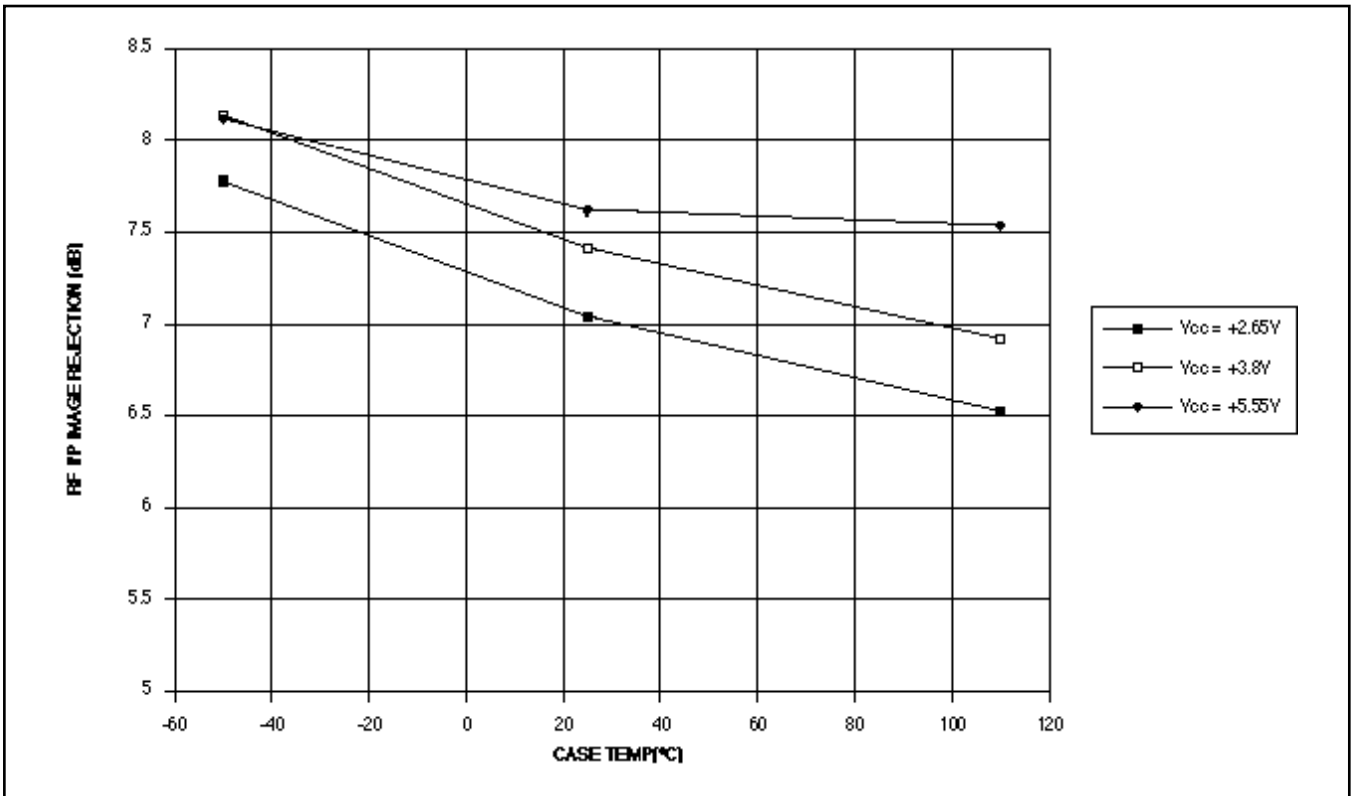

Fig. 20 Frontend/Mixer 1 Image rejection - RF I/P frequency at 1224.58MHz

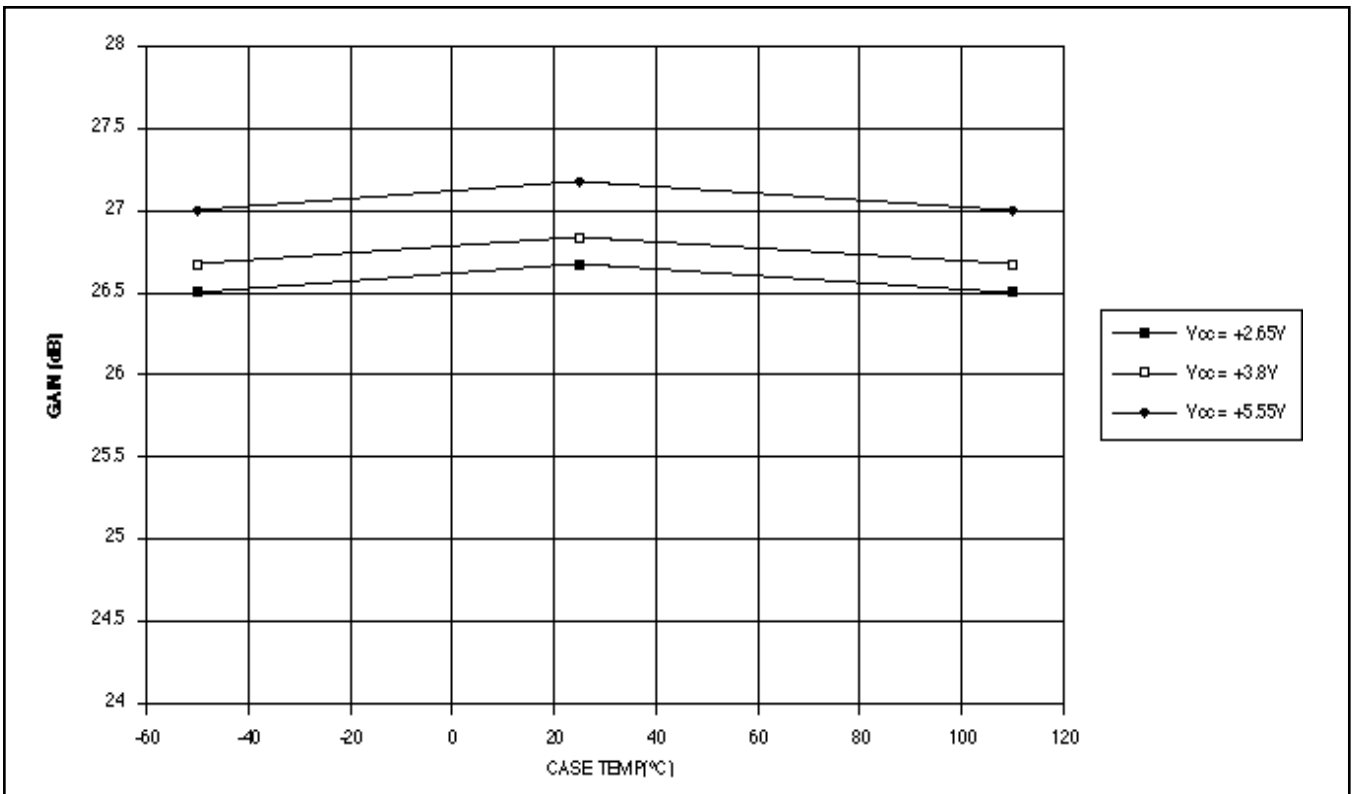

Fig. 21 Stage 2/Mixer 2 Small-signal Conversion Gain - Stage 2 I/P frequency at 175.42MHz

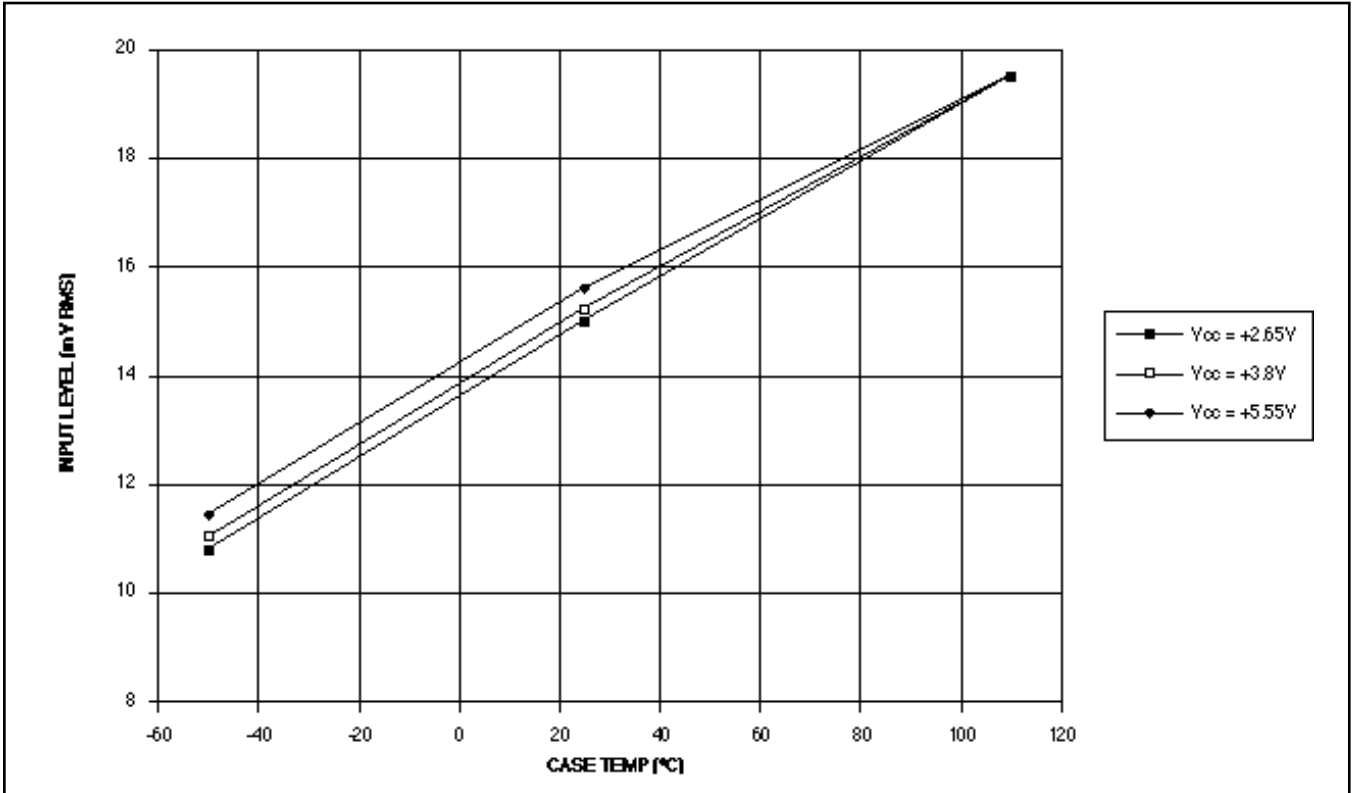

Fig. 22 Stage 2/Mixer 2 Input level for 1dB Conversion Gain-compression - Stage 2 I/P frequency at 175.42MHz

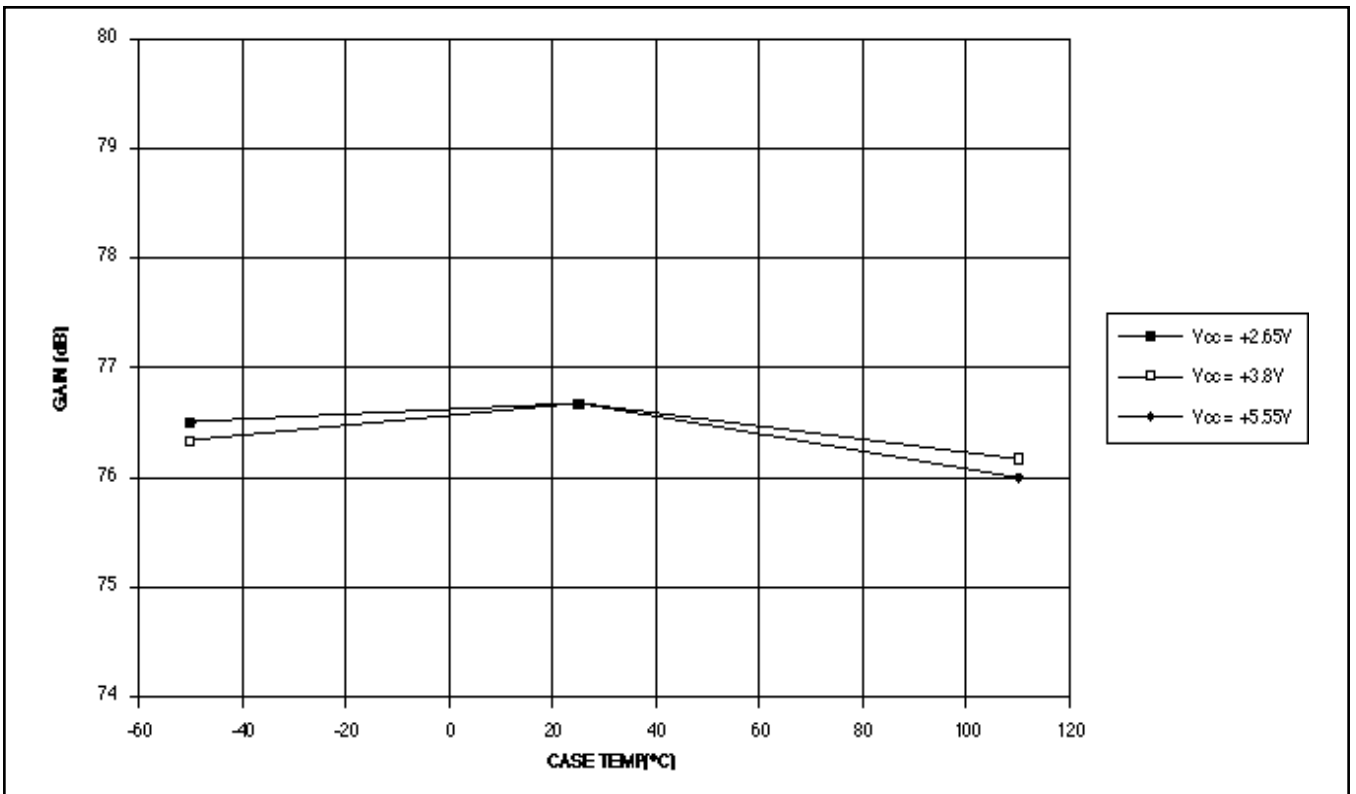

Fig. 23 Stage 3 MAXIMUM Small-signal Conversion Gain - Stage 3 I/P frequency at 35.42MHz

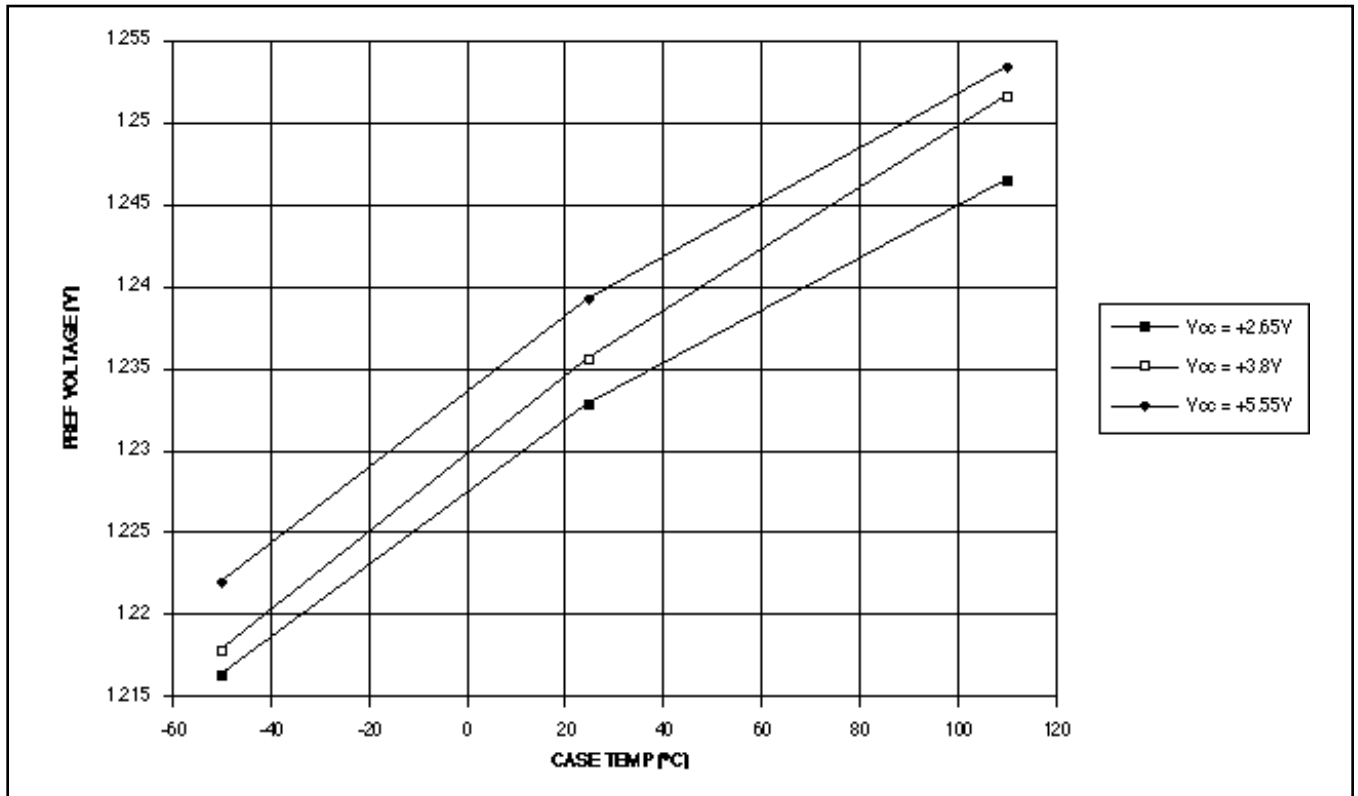

Fig. 24 Power-on Reset Threshold level

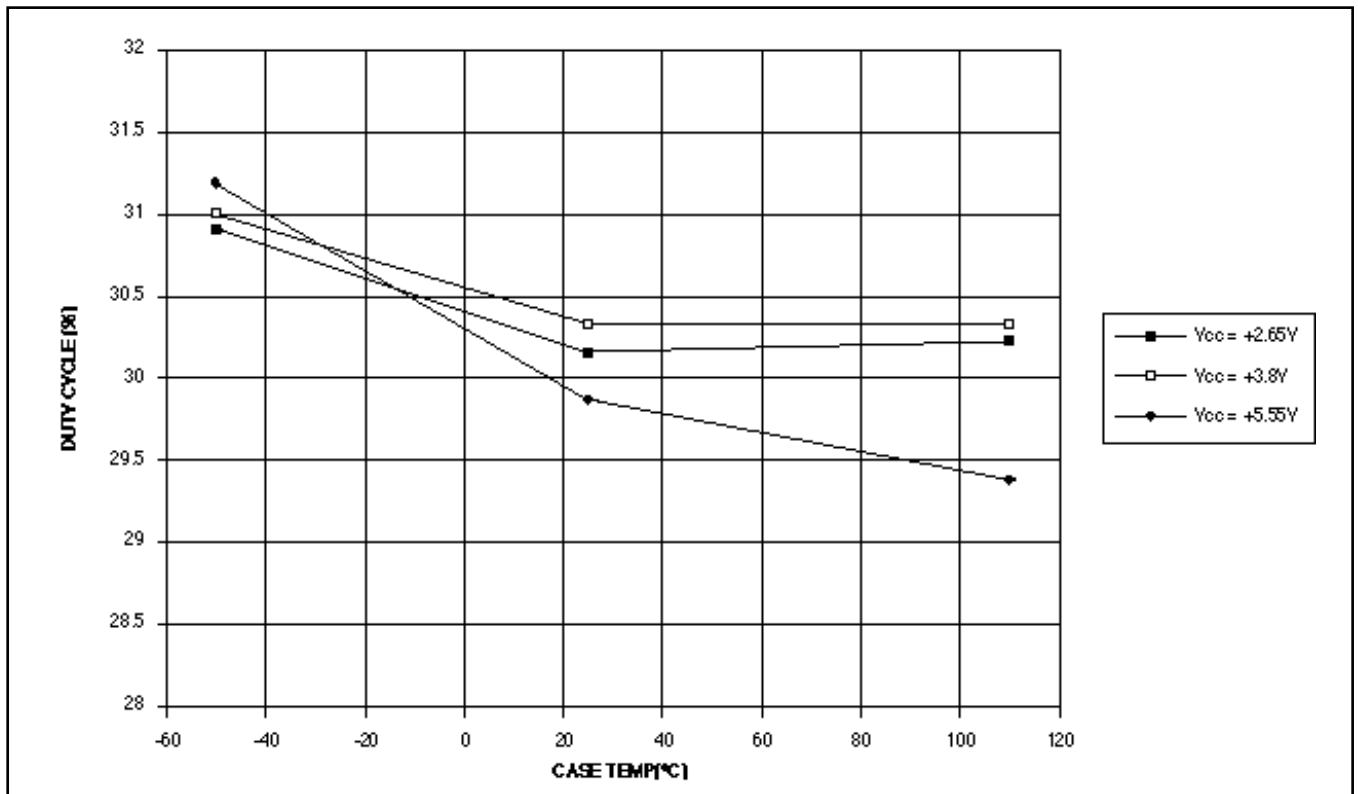

Fig. 25 Duty-cycle of MAG digital output (pin 14), sampled at 5.71MHz in a typical application circuit - RF I/P signal = 1575.42MHz CW, -85dBm - equivalent to 26dB excess noise from a typical GPS antenna

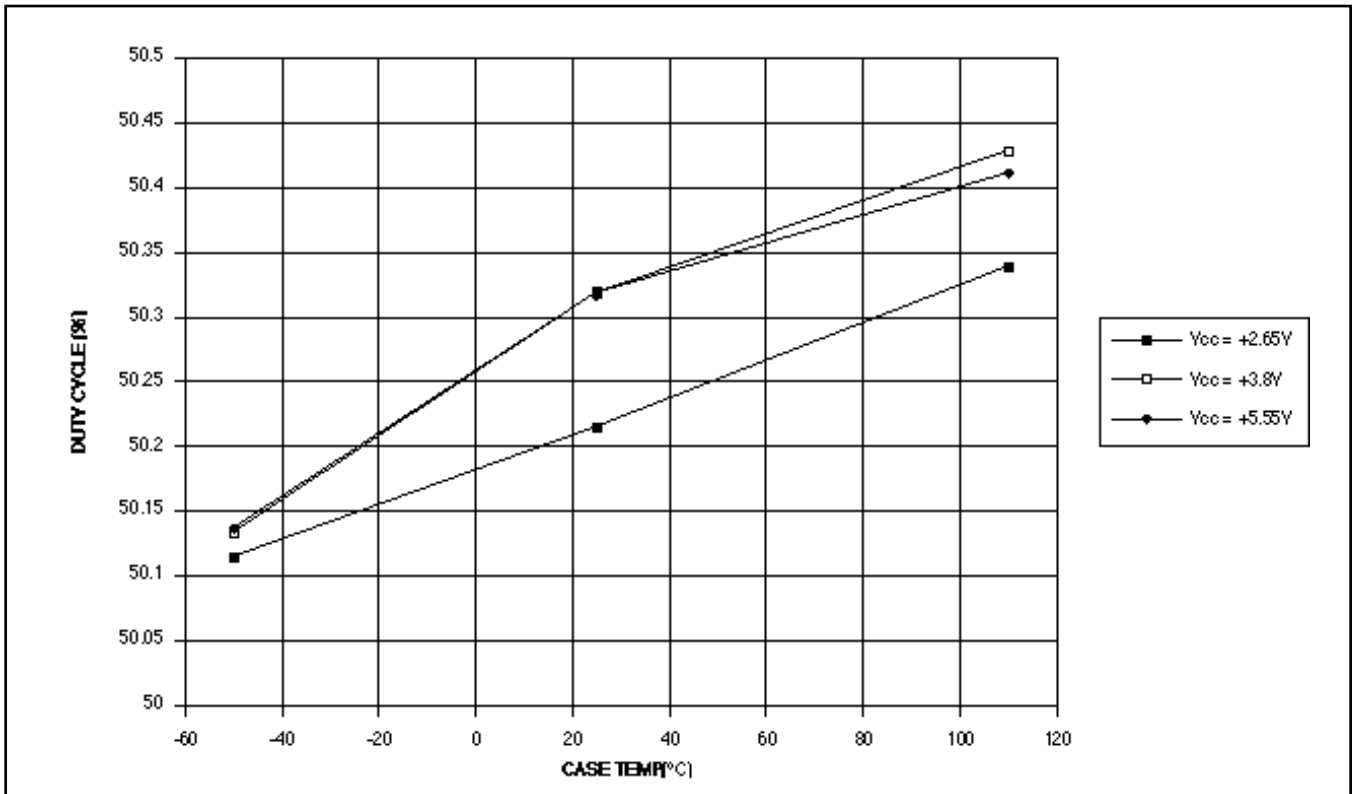

Fig. 26 Duty-cycle of SIGN digital output (pin 15), sampled at 5.71MHz in a typical application circuit  
 - RF I/P signal = 1575.42MHz CW, -85dBm - equivalent to  
 26dB excess noise from a typical GPS antenna

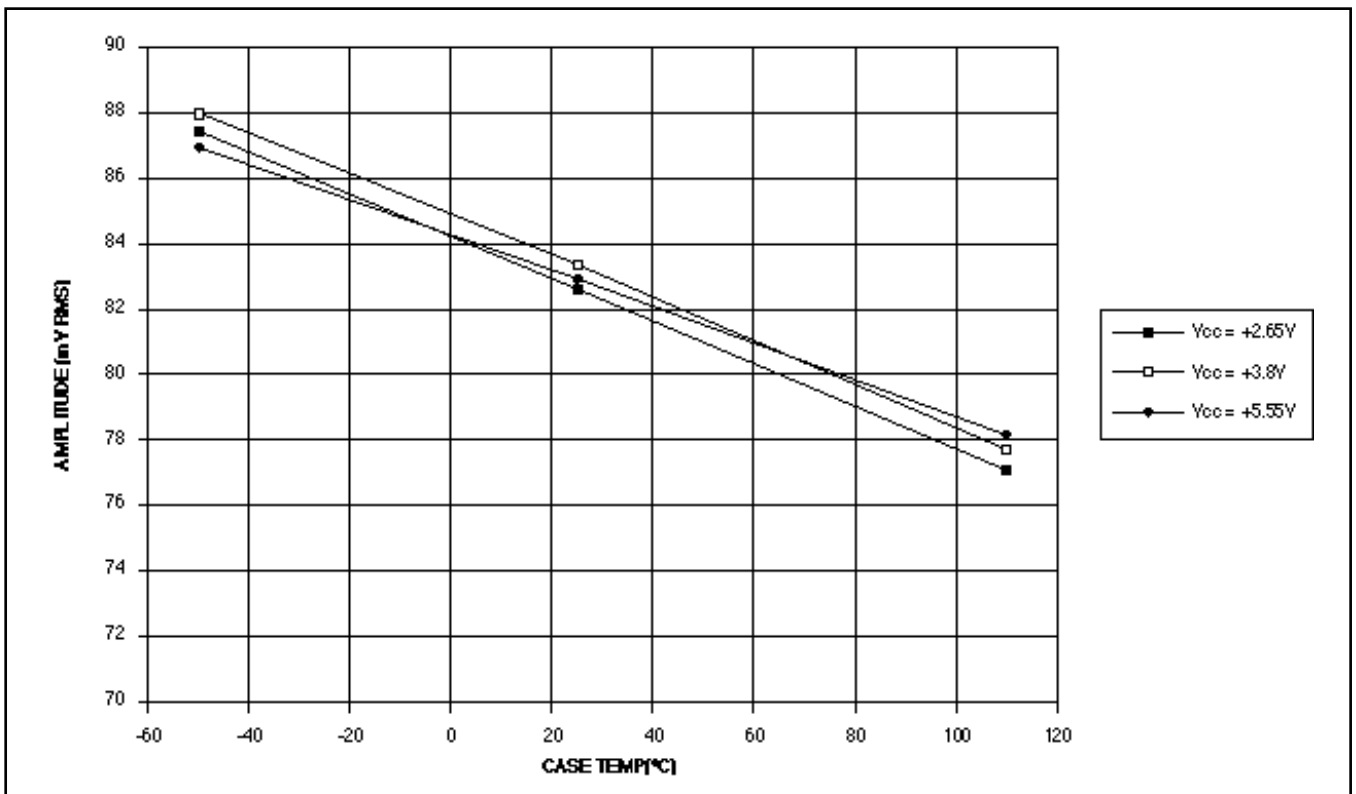

Fig. 27 Amplitude of IFOUT (pin 1) at 4.3MHz ( $\pm 1.0$ MHz) in a typical application circuit  
 - RF I/P signal = 1575.42MHz CW, -85dBm - equivalent to  
 26dB excess noise from a typical GPS antenna

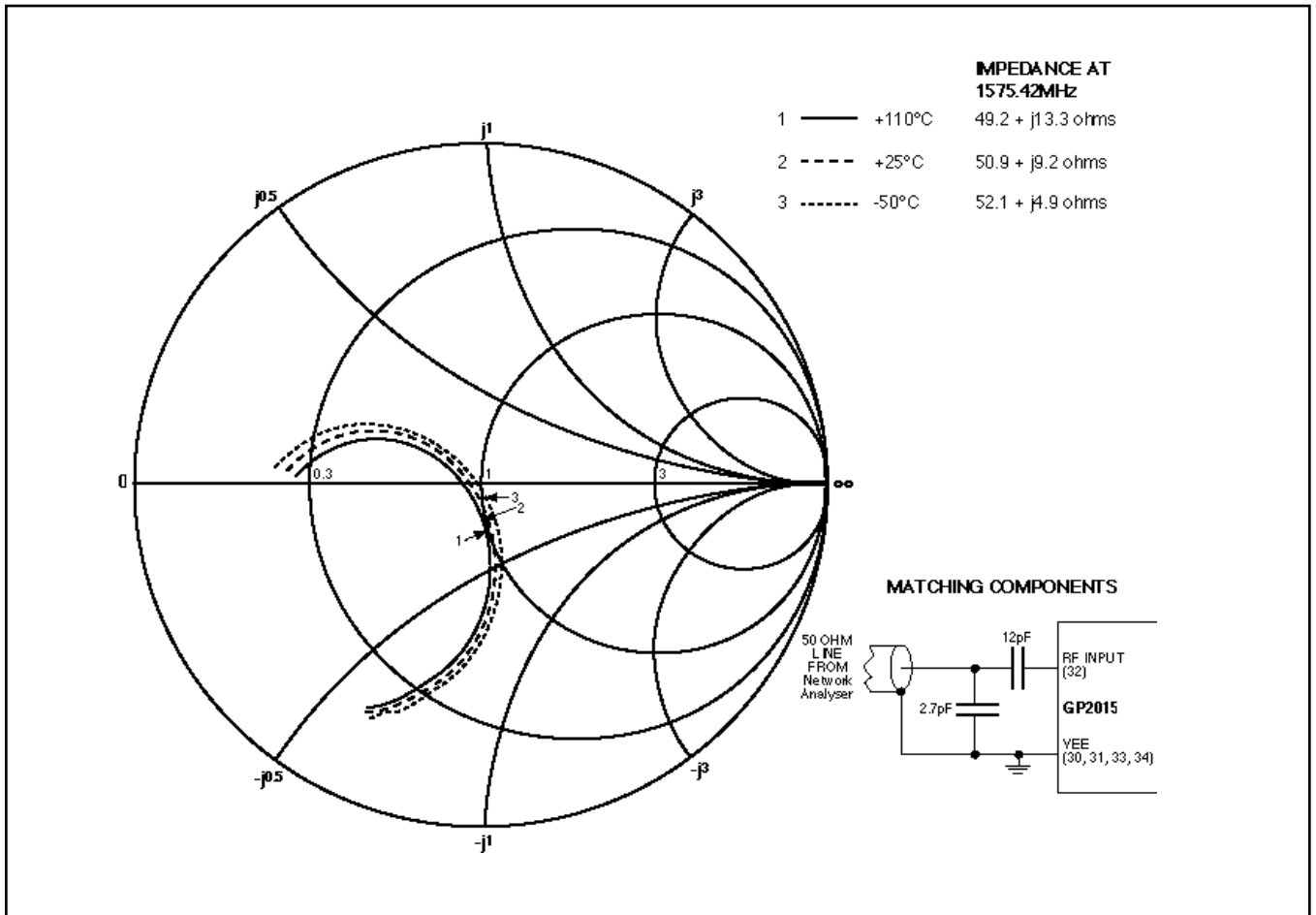
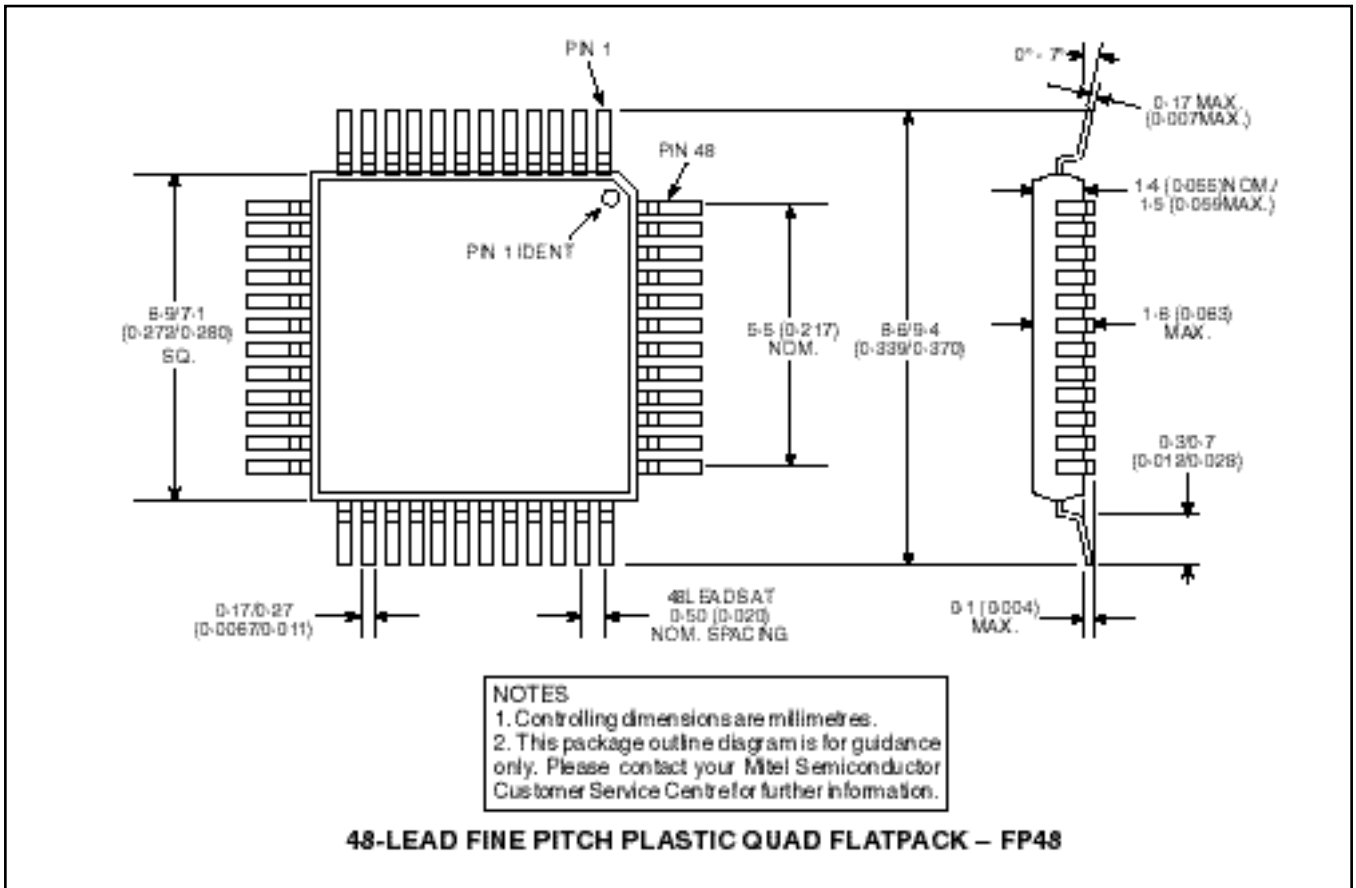

Fig. 28 Typical Matched RF I/P Impedance between 1000MHz and 2000MHz RF I/P level @ -40dBm



## PACKAGE DETAILS

Dimensions are shown thus: mm (in). For further package information, please contact your local Customer Service Centre.



### HEADQUARTERS OPERATIONS

#### MITEL SEMICONDUCTOR

Cheney Manor, Swindon,  
Wiltshire SN2 2QW, United Kingdom.  
Tel: (01793) 518000  
Fax: (01793) 518411

#### MITEL SEMICONDUCTOR

1500 Green Hills Road,  
Scotts Valley, California 95066-4922  
United States of America.  
Tel (408) 438 2900  
Fax: (408) 438 5576/6231

Internet: <http://www.gpsemi.com>

#### CUSTOMER SERVICE CENTRES

- **FRANCE & BENELUX** Les Ulis Cedex Tel: (1) 69 18 90 00 Fax : (1) 64 46 06 07
- **GERMANY** Munich Tel: (089) 419508-20 Fax : (089) 419508-55
- **ITALY** Milan Tel: (02) 6607151 Fax: (02) 66040993
- **JAPAN** Tokyo Tel: (03) 5276-5501 Fax: (03) 5276-5510
- **KOREA** Seoul Tel: (2) 5668141 Fax: (2) 5697933
- **NORTH AMERICA** Scotts Valley, USA Tel: (408) 438 2900 Fax: (408) 438 5576/6231
- **SOUTH EAST ASIA** Singapore Tel:(65) 3827708 Fax: (65) 3828872
- **SWEDEN** Stockholm Tel: 46 8 702 97 70 Fax: 46 8 640 47 36
- **TAIWAN, ROC** Taipei Tel: 886 2 25461260 Fax: 886 2 27190260
- **UK, EIRE, DENMARK, FINLAND & NORWAY**  
Swindon Tel: (01793) 726666 Fax : (01793) 518582

These are supported by Agents and Distributors in major countries world-wide.

© Mitel Corporation 1998 Publication No. DS4374 Issue No. 2.4 October 1996

TECHNICAL DOCUMENTATION – NOT FOR RESALE. PRINTED IN UNITED KINGDOM

This publication is issued to provide information only which (unless agreed by the Company in writing) may not be used, applied or reproduced for any purpose nor form part of any order or contract nor to be regarded as a representation relating to the products or services concerned. No warranty or guarantee express or implied is made regarding the capability, performance or suitability of any product or service. The Company reserves the right to alter without prior notice the specification, design or price of any product or service. Information concerning possible methods of use is provided as a guide only and does not constitute any guarantee that such methods of use will be satisfactory in a specific piece of equipment. It is the user's responsibility to fully determine the performance and suitability of any equipment using such information and to ensure that any publication or data used is up to date and has not been superseded. These products are not suitable for use in any medical products whose failure to perform may result in significant injury or death to the user. All products and materials are sold and services provided subject to the Company's conditions of sale, which are available on request.

All brand names and product names used in this publication are trademarks, registered trademarks or trade names of their respective owners.